

CATALOGO DE PARTES

*ELEVADOR
ELECTRIC*

| E 15-30



MICHIGAN®

Catalogo

1.SISTEMA DE CARROCERÍA

1.1 MONTAJE DEL MARCO.....	1
1.2 MONTAJE DEL MARCO.....	3
1.3 ASESORÍAS AÉREAS	5
1.4 PUERTA DE BARRERÍA	7
1.5 MECANISMO DE DIRECCIÓN.....	9
1.6 DISPOSITIVO DE FRENO DE MANO	11

2 SISTEMA DE CONTRAPESO

2.1 SISTEMA DE CONTRAPESO.....	13
2.2 Conjunto de transmisión.....	15

3 Sistema de elevación

3.1 MONTAJE DEL BASTIDOR EN DOS ETAPAS.....	17
3.2 COMPONENTES DEL MARCO EXTERIOR.....	19
3.3 COMPONENTES DEL MARCO INTERIOR.....	21
3.4 COMPONENTES DEL CARRO	23
3.5 CONJUNTO DE BASTIDOR DE TRIPLE MÁSTIL DE ELEVACIÓN LIBRE TOTAL	25
3.6 COMPONENTES DEL BASTIDOR EXTERIOR (MÁSTIL TRIPLE DE ELEVACIÓN LIBRE)	28
3.7 COMPONENTES DEL BASTIDOR CENTRAL (MÁSTIL TRIPLE DE ELEVACIÓN LIBRE).....	30
3.8 COMPONENTES DEL BASTIDOR INTERIOR (TRIPLE MÁSTIL DE ELEVACIÓN LIBRE).....	32
3.9 COMPONENTES DEL CARRO (MÁSTIL TRIPLE DE ELEVACIÓN LIBRE)	34

3.10 CONJUNTO DE MÁSTIL DE DOS ETAPAS DE ELEVACIÓN LIBRE TOTAL	36
3.11 COMPONENTES DEL BASTIDOR EXTERIOR (MÁSTIL DE DOS ETAPAS DE ELEVACIÓN LIBRE)	39
3.12 COMPONENTES DEL BASTIDOR INTERIOR (MÁSTIL DE DOS ETAPAS DE ELEVACIÓN LIBRE).....	41
3.13 COMPONENTES DEL CARRO (MÁSTIL DE DOS ETAPAS DE ELEVACIÓN LIBRE).....	43
4. Conjunto de la tapa de la batería	
4.1 MONTAJE DE LA TAPA DE LA BATERÍA	45
5. Cobertura del cuadro de mando	
5.1 COBERTURA DEL CUADRO DE MANDO.....	47
6. Sistema hidráulico	
6.1 SISTEMA HIDRÁULICO	49
7. Sistema eléctrico	
7.1 DK1232-01 COMPONENTES DE CONTROL ELÉCTRICO DE CORRIENTE ALTERNA... 51	51

1.1 Montaje del marco

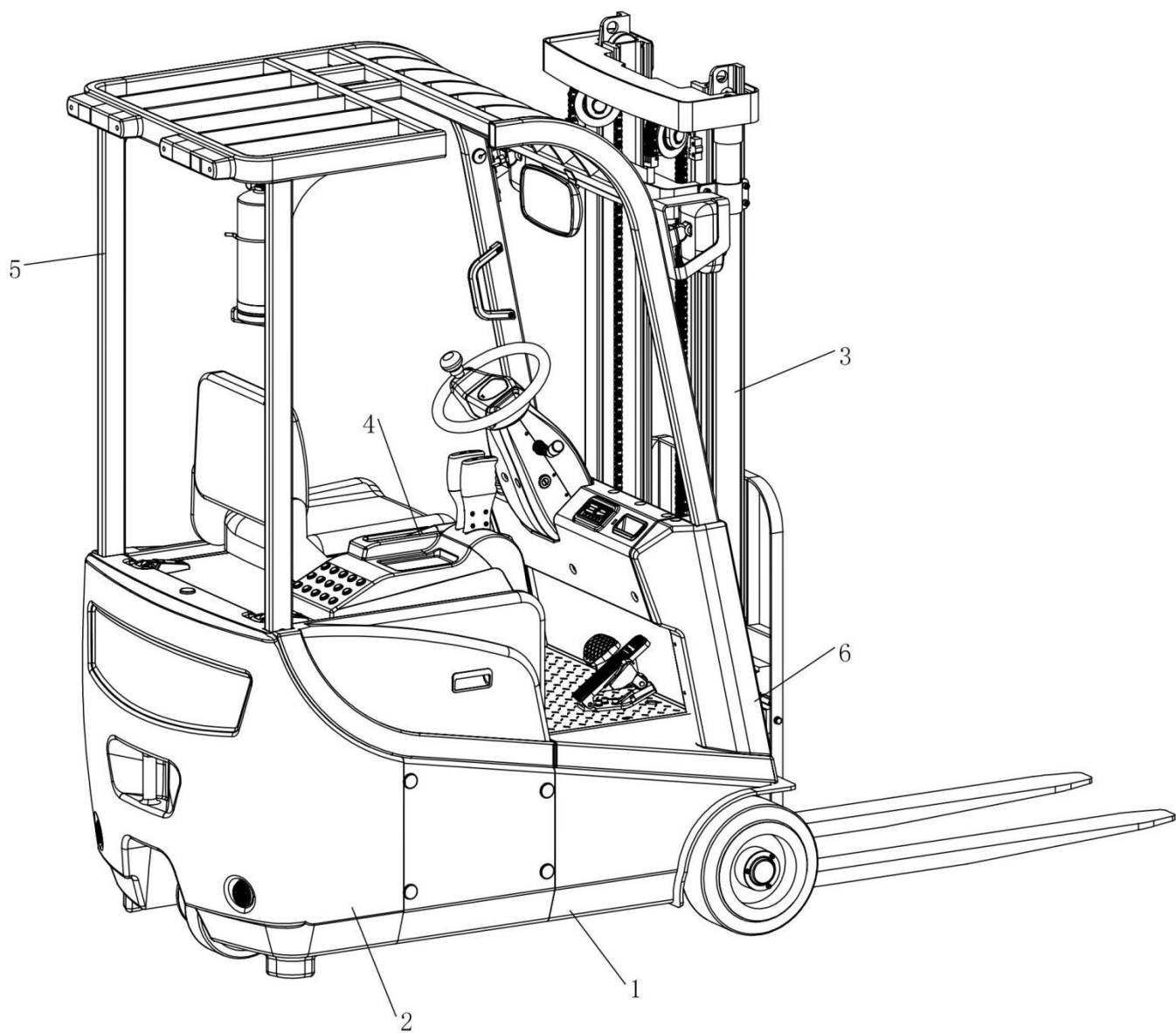

1.1 Montaje del marco

No	Code	Description	Specification	Quantity	Remark
1	E10GS-06.4	Column front cover		1	
2	E10GS-06.5	Column rear cover		1	
3	E10GS-06.2	Dashboard side cover (Left)		1	
4	E10GS-04.5	Multiply valve mask		1	
5	E10GS-06.1	Dashboard cover		1	
6	E10GS-06.3	Dashboard side cover (Right)		1	
7	E10GS-01.14	Left side cover		1	

1.1 Montaje del marco

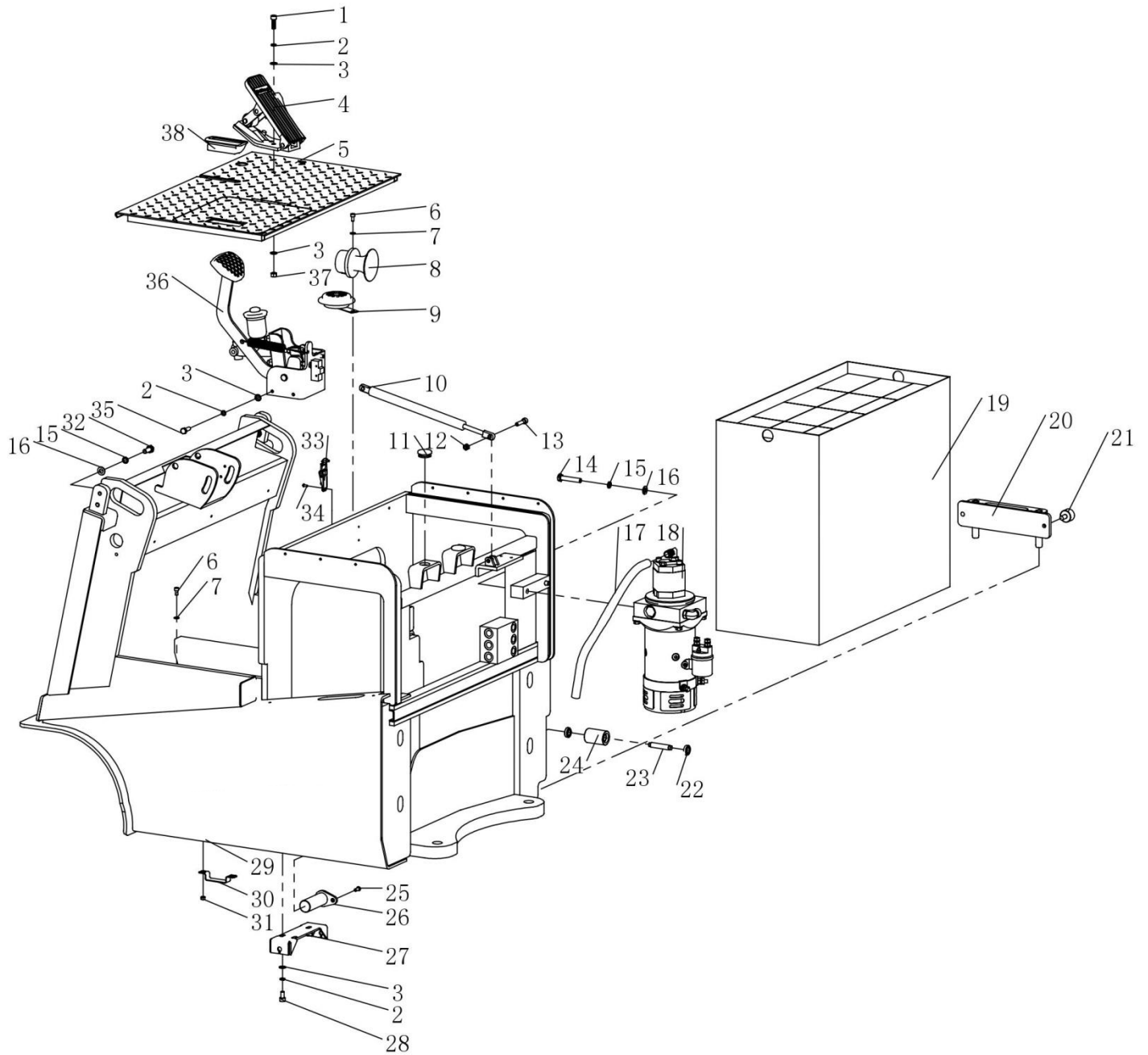

1.2 Montaje del marco

No	Código	Descripción	Especificación	Cantidad	Obvs.
1	GB/T 70.1-2000	Hexagon socket head cap screws	M8×25	3	
2	GB/T 93-1987	Spring washer	Φ8	10	
3	GB/T 97.2-1985	Flat washer	Φ8	13	
4	TY-01.23	DTJ01301 Accelerator		1	
5	E10GS-01.5	Foot pedal welding parts		1	
6	GB/T 70.1-2000	Hexagon socket head cap screws	M6×12	3	
7	GB/T 97.2-1985	Flat washer	Φ6	4	
8	TY-01.29	Reversing alarm		1	
9	TY-01.18	Horn DC24-Φ125		1	
10	E10GS-01.9	Gas spring	600N	1	
11	CS1232.8-1	Crash pad		2	
12	GB/T 6184-2000	Hexagon lock nut	M8	1	
13	GB/T 70.1-2000	Hexagon socket head cap screws	M8×35	1	
14	GB/T 5781-2000	Hexagon head bolt full thread	M10×55	2	
15	GB/T 93-1987	Spring washer	Φ10	6	
16	GB/T 97.2-1985	Flat washer	Φ10	6	
17		Cotton Resistance tubing	Φ16	1	
18	E10GS-01.7	Power unit		1	
19	E10GS-01.10	Battery	5VBS350	1	
20	E10GS-01.18	Battery Baffle		1	
21	GB 835-1988	Knurled screws	M10×20	2	
22	GB/T 276-94	Deep groove ball bearing	61901	16	
23	E10GS-01.13	Battery roller shaft		8	
24	E10GS-01.12	Battery roller		8	
25	GB/T 70.2-2000	Hexagon socket head cap screws	M6×16	1	
26	E10GS-01.6	Inclined oil cylinder components		1	
27	E10GS-01.16	Brake line frame		1	
28	GB/T 70.1-2000	Hexagon socket head cap screws	M8×16	3	
29	E10GS-01.1	Main frame welded		1	
30	E10GS-01.11	Snail joint		4	
31	GB/T 6170-2000	Hexagon nut	M6	8	
32	GB/T 5781-2000	Hexagon head bolt full thread	M10×25	4	

33	TY-02.11	No 2 flat mouth buckle 5103B		1	
34	GB/T 70.2-2000	Hexagon socket head cap screws	M4×10	4	
35	GB/T 5783-2000	Hexagon head bolt full thread	M8×25	4	
36	E10GS-01.4	Foot brake assembly		1	
37	GB/T 41-2000	Hexagon nut	M8	3	
38	TY-02.8	Embedded handle		1	

1.3 Asesorías aéreas

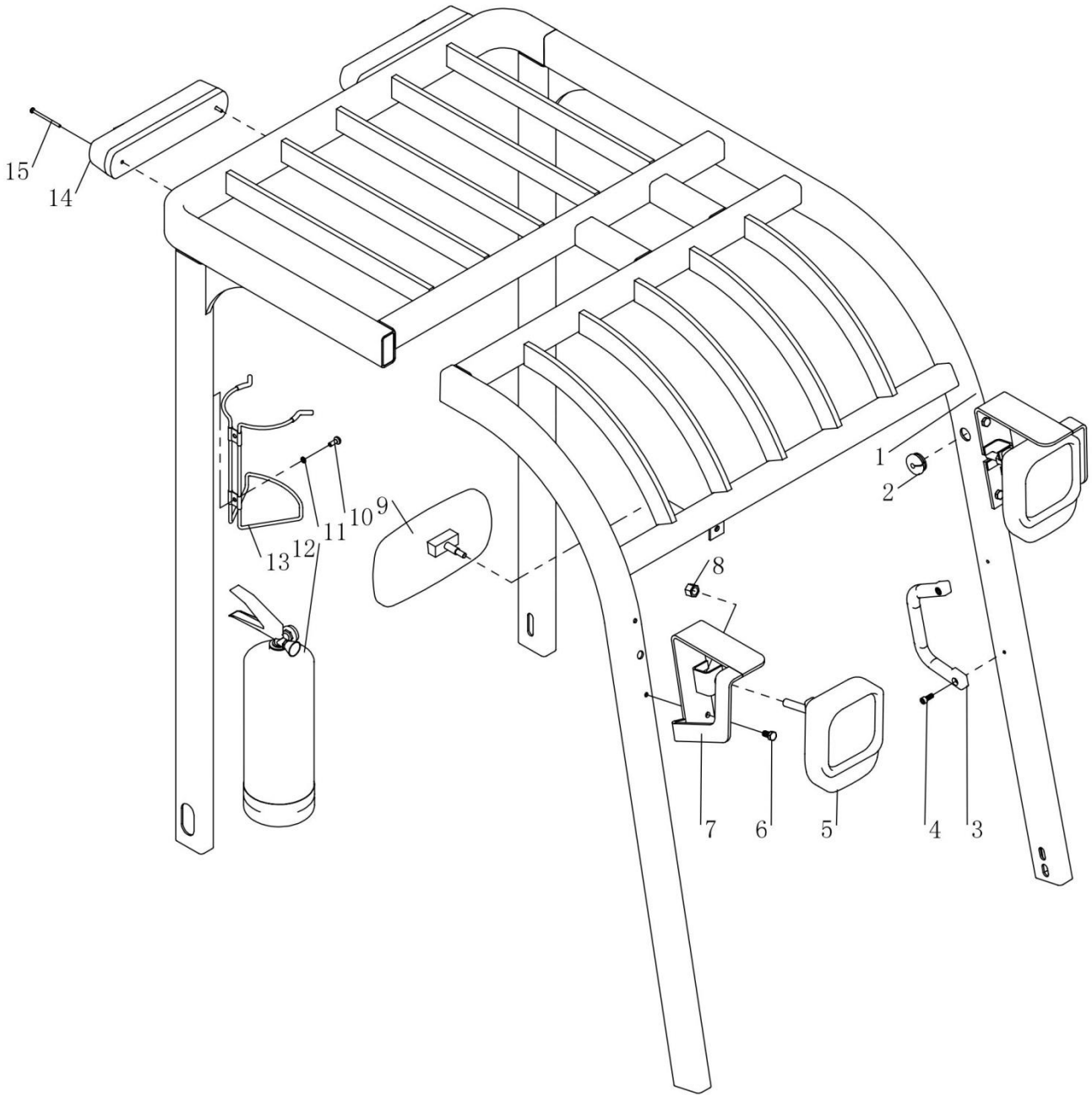

1.3 Asesorías aéreas

Nº .	Código	Descripción	Especificación	Cantidad	Observ
1	E10GS-05.1	Overheard welded		1	
2	CS1232.8-1	Crash pad		3	
3	TY-02.18	Handle		1	
4	GB/T 70.1-2000	Hexagon socket head cap screws	M6×16	2	
5	HD105×105-1	Headlamp		2	
6	GB/T 5781-2000	Hexagon bolt	M8×16	4	
7	E10GS-05.3.1	Protective cover welding		2	
8	GB/T 41-2000	Hexagon nut	M12	2	
9	TY-02.19	Rearview mirror rHS200×110		1	
10	GB/T 818-2000	Cross recessed pan head screw	M6×16	2	
11	GB/T 93-1987	Spring washer	Φ6	2	
12		2KG fire extinguisher		1	
13	TY-02.16	2KGfire extinguisher bracket		1	
14	TY-01.27	Three color rear lamp XH8-65	24V	2	
15	GB/T 818-2000	Cross recessed pan head screw	M4×60	2	

1.4 Puerta de batería

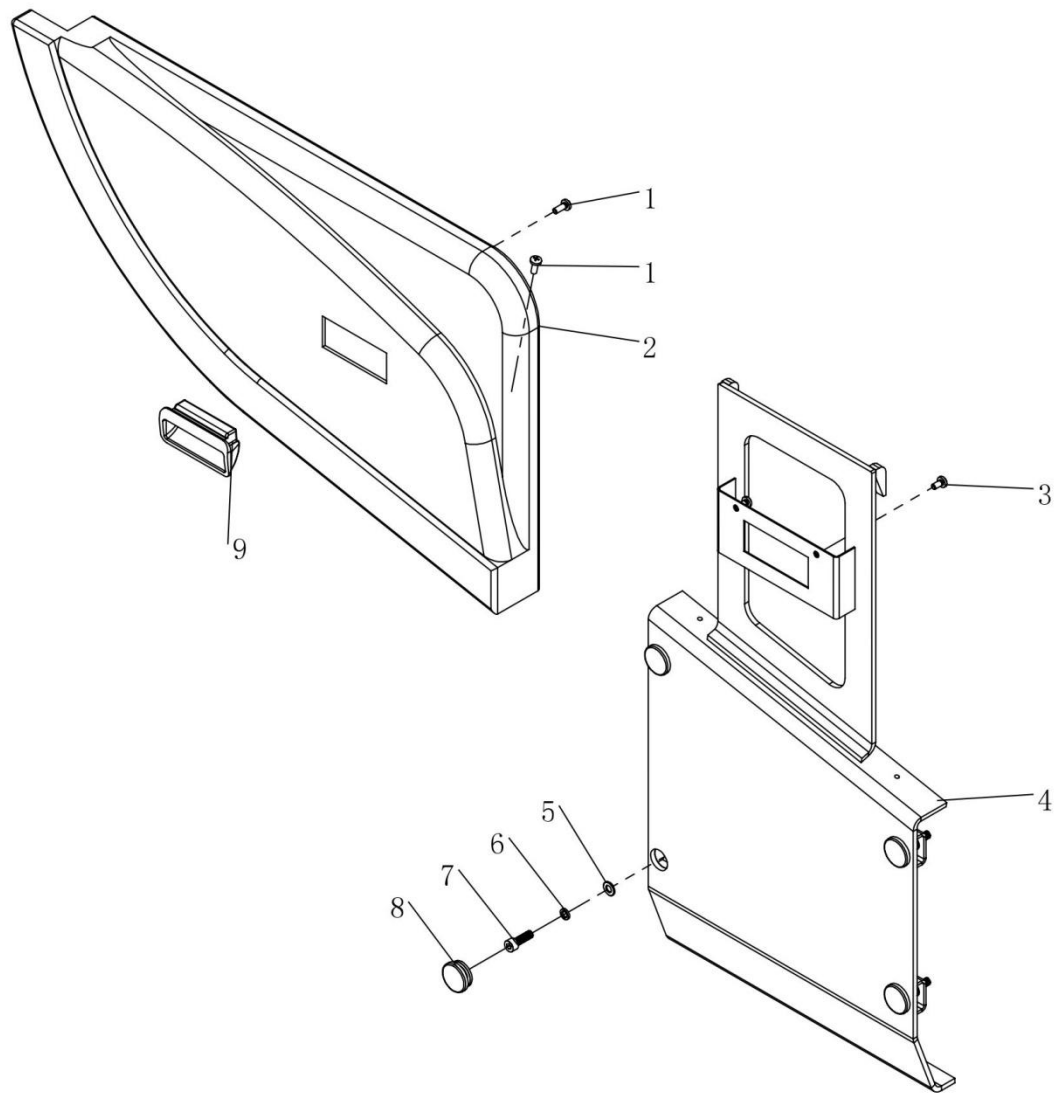

1.4 Puerta de batería

N° .	Código	Descripción	Especificación	Cantidad	Observ
1	GB/T 818-2000	Cross recessed pan head screw	M6×16	6	
2	E10GS-01.2.1	Right side cover		1	
3	GB/T 818-2000	Cross recessed pan head screw	M6×12	2	
4	E10GS-01.2.1	Battery door welding		1	
5	GB/T 97.2-1985	Flat washer	Φ8	4	
6	GB/T 93-1987	Spring washer	Φ8	4	
7	GB/T 70.1-2000	Hexagon socket head cap screws	M8×25	4	
8	CS1232.8-1	Crash pad		4	
9	TY-02.8	Embedded handle		1	

1.5 Mecanismo de dirección

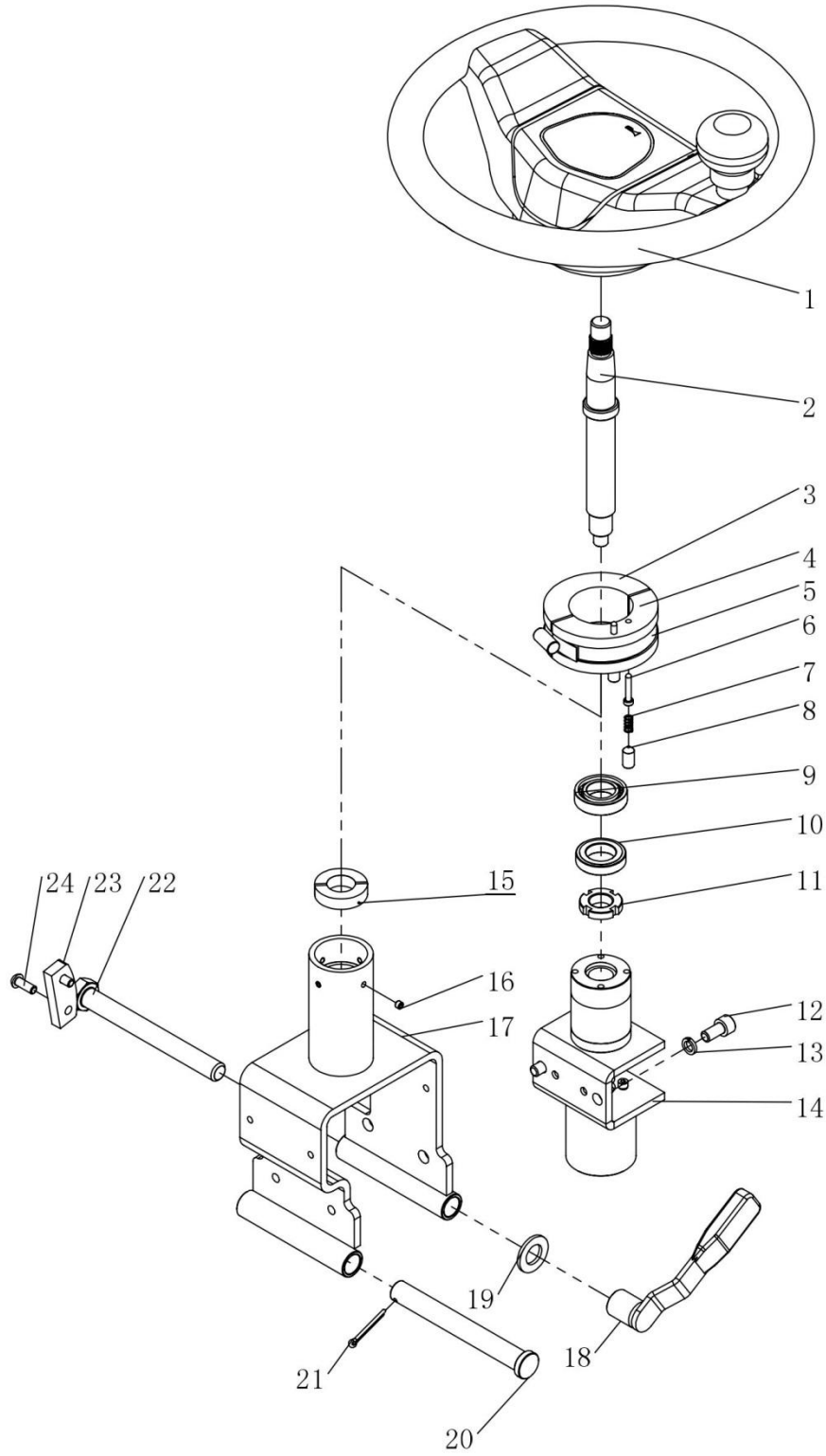

1.5 Mecanismo de dirección

Nº .	Código	Descripción	Especificación	Cant.	Observ
1	249M4-10201	Steering wheel		1	
2	E10GS-01.3.7	Steering rod		1	
3	E10GS-01.3.3.2	Nylon ring 2		1	
4	E10GS-01.3.3.1	Nylon ring1		1	
5		Clamp	59-82	1	
6	E10GS-01.3.3.3	Contact lever		2	
7		Pressure spring 0.6×6×10		2	
8	GB/T 78-2000	Hexagon socket end set screws	M8×16	2	
9	GB/T 276-94	Deep groove ball bearing	61904	1	
10	E10GS-01.3.4	Washer		1	
11	GB/T 812-1988	Round nut	M16×1.5	1	
12	GB/T 70.1-2000	Hexagon socket head cap screws	M8×16	2	
13	GB/T 93-1987	Spring washer	Φ8	2	
14	E10GS-01.3.9	Steering sensor assembly		1	
15	E10GS-01.3.8	Nylon damping block		2	
16	GB/T 77-2000	Hexagon flat end set screws	M5×4	4	
17	E10GS-01.3.1	Directional column welding		1	
18	E10GS-01.3.2	Adjustment handle welding		1	
19	GB/T 95-2002	Flat washer	Φ14	1	
20	E10GS-01.3.6	Connecting pin		1	
21	GB/T 91-2000	Cotter pin	Φ3.2×28	1	
22	GB/T 5780-2000	Hexagon bolt	M14×130	1	
23	E10GS-01.3.5	Bolt limit block		1	
24	GB/T 70.2-2000	Hexagon socket head cap screws	M6×16	2	

1.6 Dispositivo de freno de mano

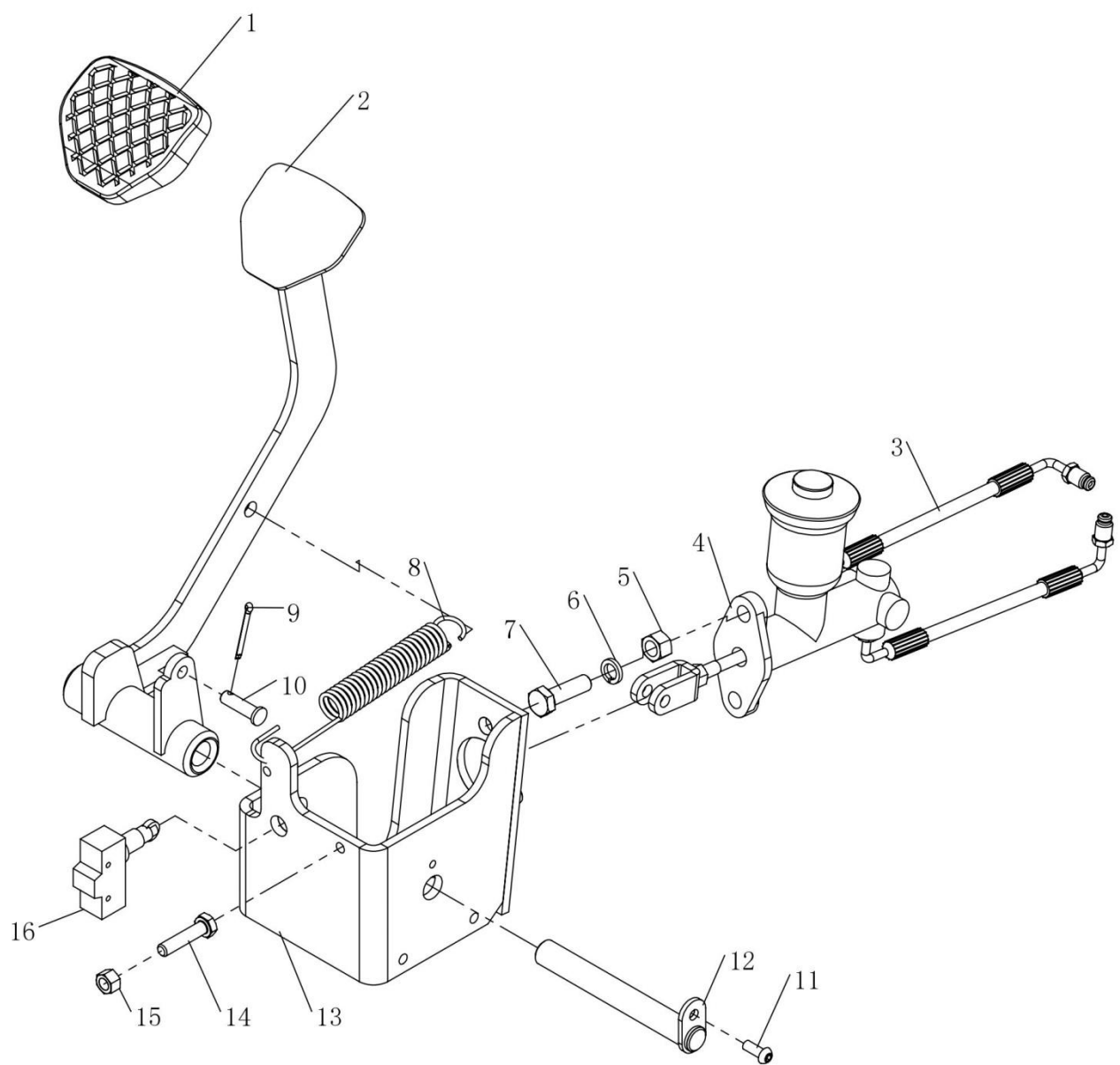

1.6 Dispositivo de freno de mano

Nº .	Código	Descripción	Especificación	Cantidad	Observ
1		Pedal Leather		1	
2	E10GS-01.4.2	Brake Pedal		1	
3	E10GS-01.4.6	Brake pipe		2	
4		Brake pump		1	
5	GB/T 41-2000	Hexagon nut	M10	2	
6	GB/T 93-1987	Spring Washer	Φ10	2	
7	GB/T 5781-2000	Hexagon head bolt full thread	M10×35	2	
8	E10GS-01.4.5	Spring		1	
9	GB/T 91-2000	Cotter pin	Φ3.2×28	1	
10	E10GS-01.4.4	Rod jaw pin		1	
11	GB/T 70.2-2000	Hexagon socket head cap screws	M6×16	1	
12	E10GS-01.4.3	Foot brake lug shaft		1	
13	E10GS-01.4.1	Bracket welded		1	
14	GB/T 5781-2000	Hexagon head bolt full thread	M8×35	1	
15	GB/T 41-2000	Hexagon nut	M8	1	
16	TY-01.33	Micro switchRZ-15GQ22-B3		1	

2.1 Sistema de contrapeso

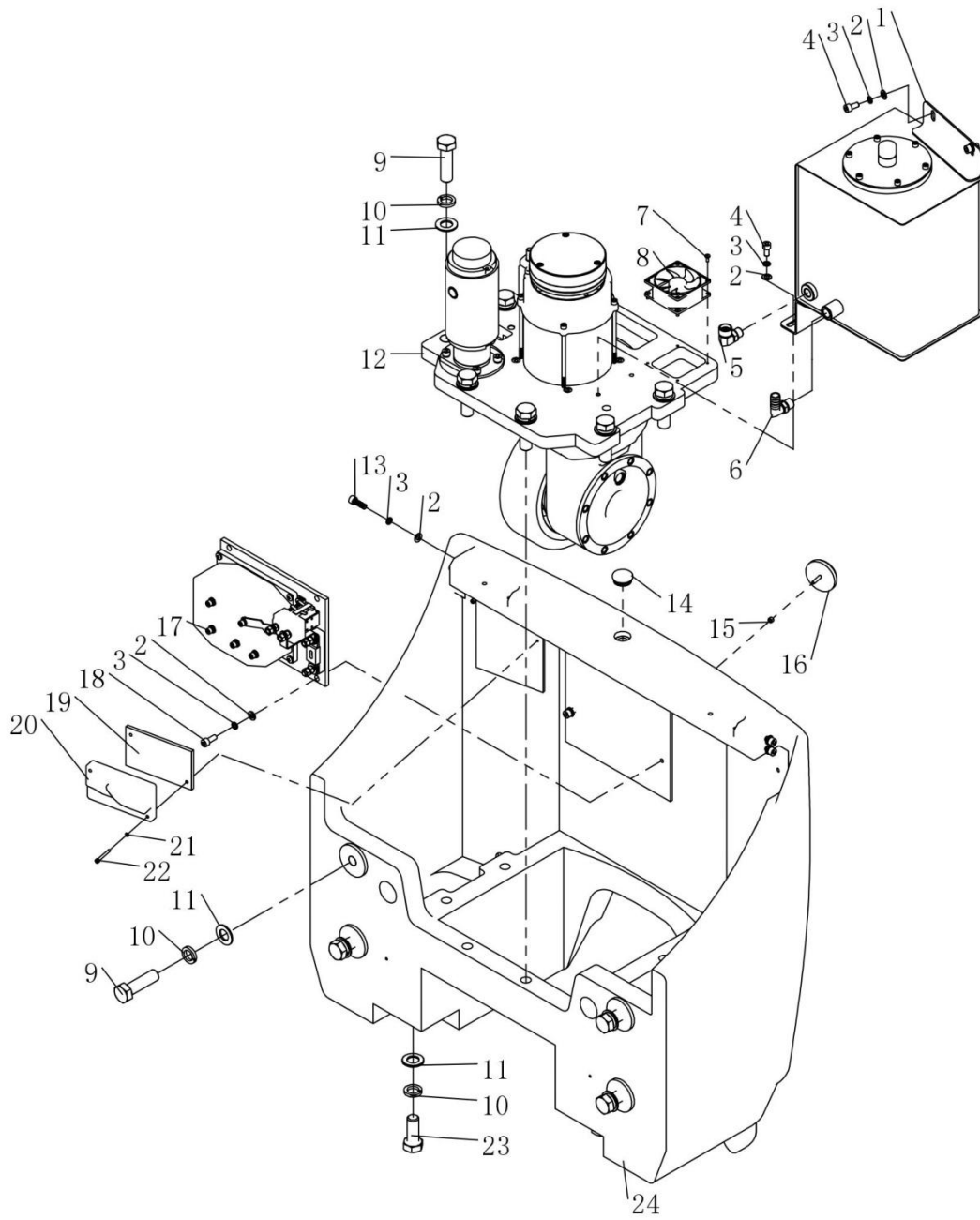

2.1 Sistema de contrapeso

Nº .	Código	Descripción	Especificación	Cantidad	Observ
1	E10GS-02.1	Tank ASSY fuel		1	
2	GB/T 97.2-1985	Flat washer	Φ8	12	
3	GB/T 93-1987	Spring washer	Φ8	12	
4	GB/T 70.1-2000	Hexagon socket head cap screws	M8×16	4	
5	E10GS-02.6	Right angle adjustable joint		1	
6	E10GS-02.5	Pump suction port connector		1	
7	GB/T 818-2000	Cross recessed pan head screw	M4×10	8	
8	TY-01.28	Air fan	80×80	2	
9	GB/T 5782-2000	Hexagon bolt	M20×70	10	
10	GB/T 93-1987	Spring washer	Φ20	12	
11	GB/T 97.2-1985	Flat washer	Φ20	12	
12	E10GS-02.2	Vertical drive steering assembly		1	
13	GB/T 70.1-2000	Hexagon socket head cap screws	M8×25	4	
14	CS1232.8-1	Crash pad		1	
15	GB/T 41-2000	Hexagon nut	M5	2	
16	TY-02.17	Retroreflector XH6-4-00		2	
17	DK1232-01	AC electric control components		1	
18	GB/T 70.1-2000	Hexagon socket head cap screws	M8×20	4	
19	DK1220-01.1	Electrically control mounting plate		1	
20	1212P-2502	Electric steering		1	
21	GB/T 93-1987	Spring washer	Φ4	2	
22	GB/T 70.1-2000	Hexagon socket head cap screws	M4×35	2	
23	GB/T 5781-2000	Hexagon head bolt full thread	M20×50	2	
24	E10GS-02.3	Three point weight		1	

2.2 Conjunto de transmisión

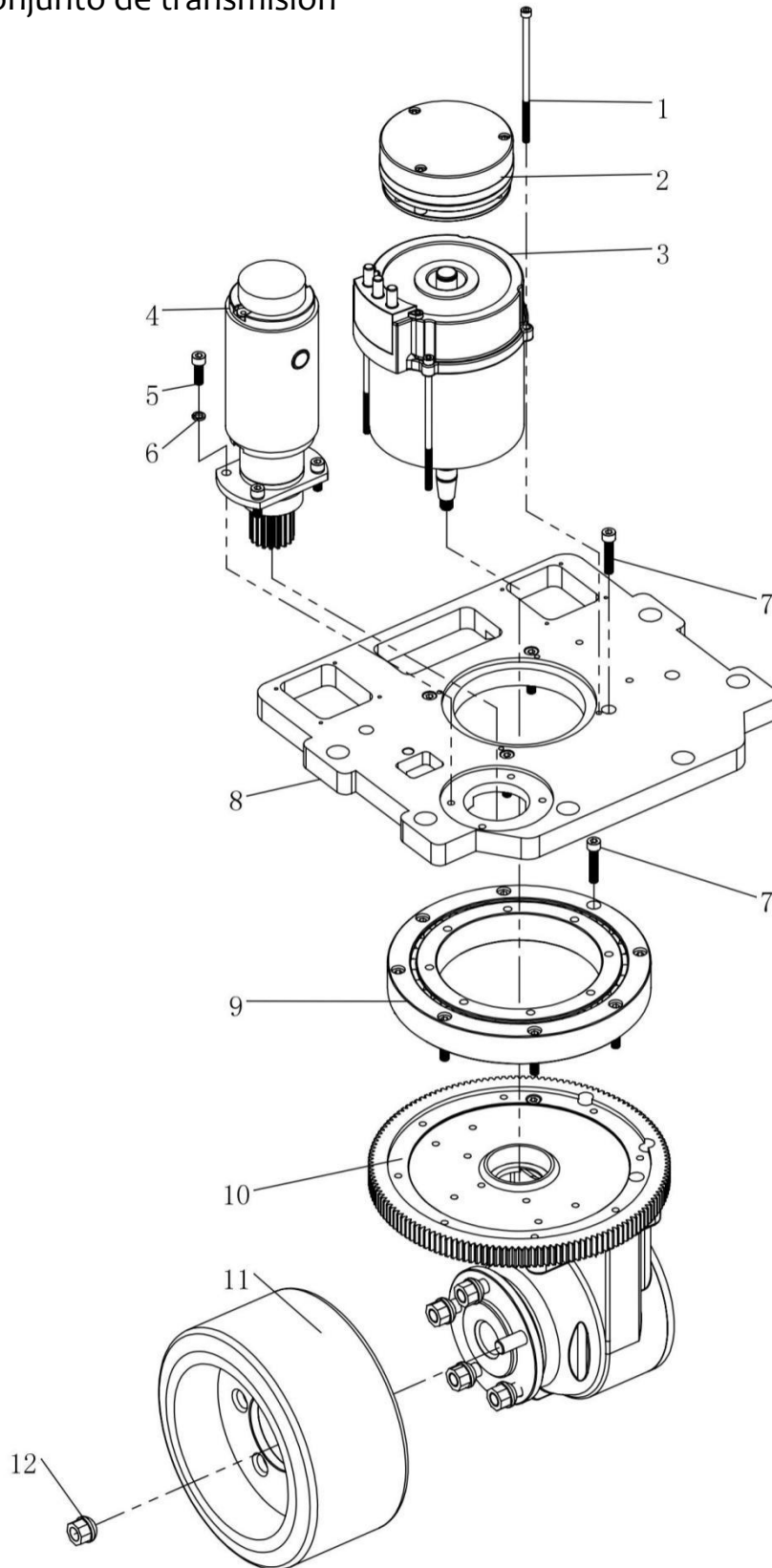

2.2 Conjunto de Transmisión

Nº .	Código	Descripción	Especificación	Cantid.	Observ
1	GB/T 70.1-2000	Hexagon socket head cap screws	M6×150	4	
2	QD1545.24-2	Electromagnetic brake magnetic sensor assembly.		1	
3	QD1545.24-3	AC Motor	1.5KW	1	
4	TY-01.8	Steering motor	0.2KW	1	
5	GB/T 70.1-2000	Hexagon socket head cap screws	M8×25	4	
6	GB/T 93-1987	Spring Washer	Φ8	16	
7	GB/T 70.1-2000	Hexagon socket head cap screws	M8×40	12	
8	E10GS-02.2.1	Vertical drive connection board		1	
9	DCU12-02-24	Large slewing bearing		1	
10	ZD-ZV21-500-001	Vertical gearbox assembly		1	
11	E10GS-02.2.2	Driving wheel		1	
12	GB/T 804-1988	Spherical hexagon nut	M14	5	

3.1 Montaje del bastidor en dos etapas

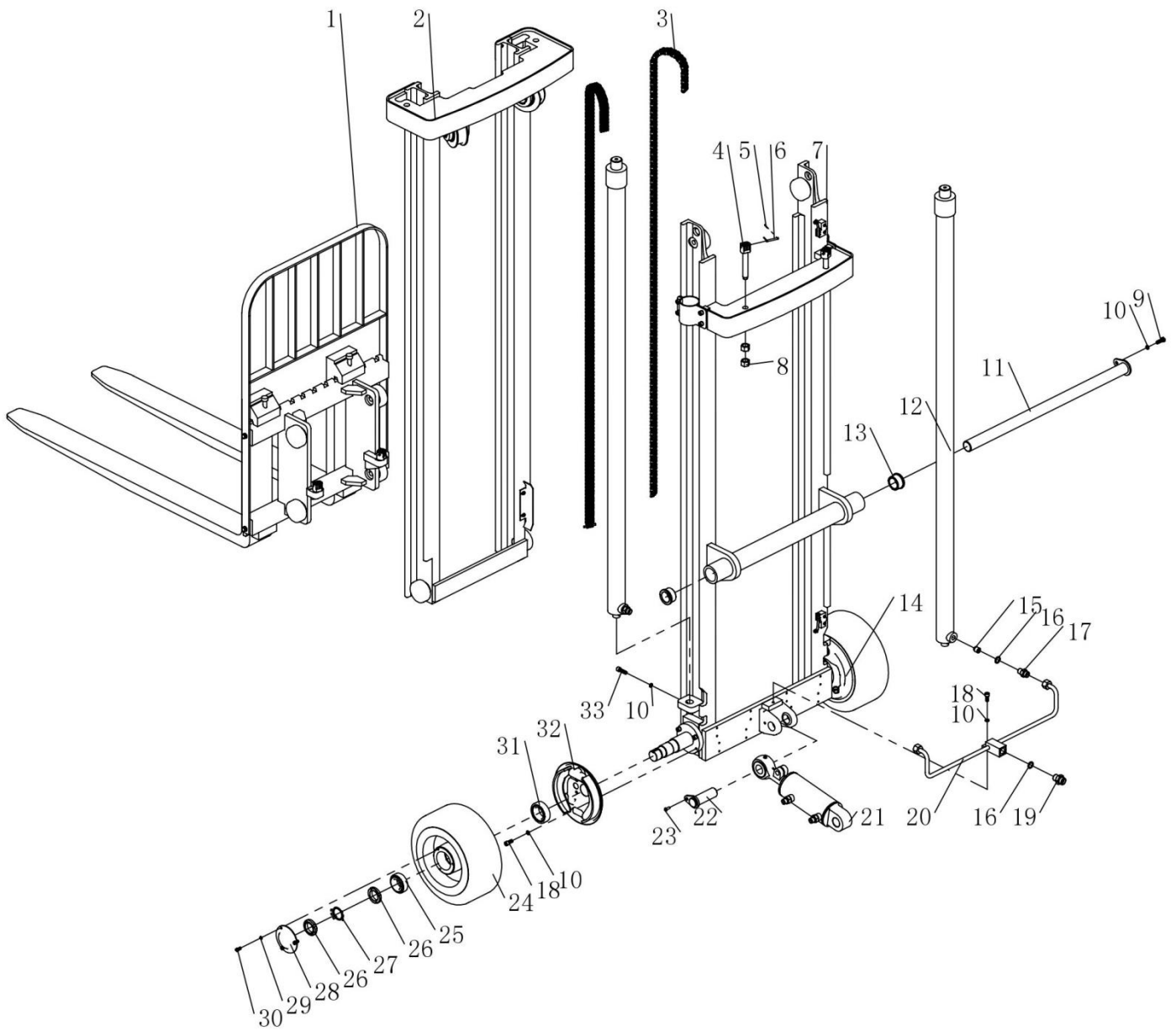

3.1 Montaje del bastidor en dos etapas

Nº .	Código	Descripción	Especificación	Cantidad	Observ
1	E10GS-03.3	Carriage components		1	
2	E10GS-03.2	Inner frame components		1	
3	LH0866	Leaf chain		2	
4	CG1646.02-4	Chain bolt		2	
5	GB/T 91-2000	Cotter pin	Φ1.2×18	8	
5.1	GB 880-86	Pins with split pin hole	Φ5×40	4	
6	E10GS-03.1	Outer frame components		1	
7	GB/T 41-2000	Hexagon Nut	M16	4	
8	GB/T 5781-2000	Hexagon bolt	M8×25	1	
9	GB/T 93-1987	Spring washer	Φ8	12	
10	E10GS-03.7	Transmission shaft welded		1	
11	E10GS-03.4	Lifting cylinder components		2	
12	E10GS-03.10	Mast connect copper sleeve		2	
13	S11-3502020	Brake assembly Right		1	
14	CL10.4.3	Anti-explosion valve spool		1	
15	GB982-77	Combination gasket	Φ16	3	
16	E10GS-01.8.7	Straight Adapter		2	
17	GB/T 70.1-2000	Hexagon socket head cap screws	M8×20	9	
18	E10GS-03.12	Straight Adapter		1	
19	E10GS-03.9	Steel pipe		1	
20	E10GS-03.5	Inclined oil cylinder components		1	
21	E10GS-01.6	Inclined oil cylinder Pin shaft welded		1	
22	GB/T 70.2-2000	Hexagon socket flat head cap screws	M6×16	1	
23	CPD10A	Front wheel	Φ305×127	2	
24	GB/T 297-94	Tapered roller bearing	33007	2	
25	GB/T 812-1988	Round nut	M35×1.5	4	
26	GB 858-1988	Round nut with stop washer	Φ35	2	
27	E10GS-03.11	Front wheel side cover		2	
28	GB/T 93-1987	Spring washer	Φ6	6	
29	GB/T 65-2000	Slotted cap screw	M6×14	6	
30	GB/T 297-94	Tapered roller bearing	33008	2	
31	S11-3502020	Brake assembly left		1	
32	GB/T 70.1-2000	Hexagon socket head cap screws	M8×30	2	

3.2 Componentes del marco exterior

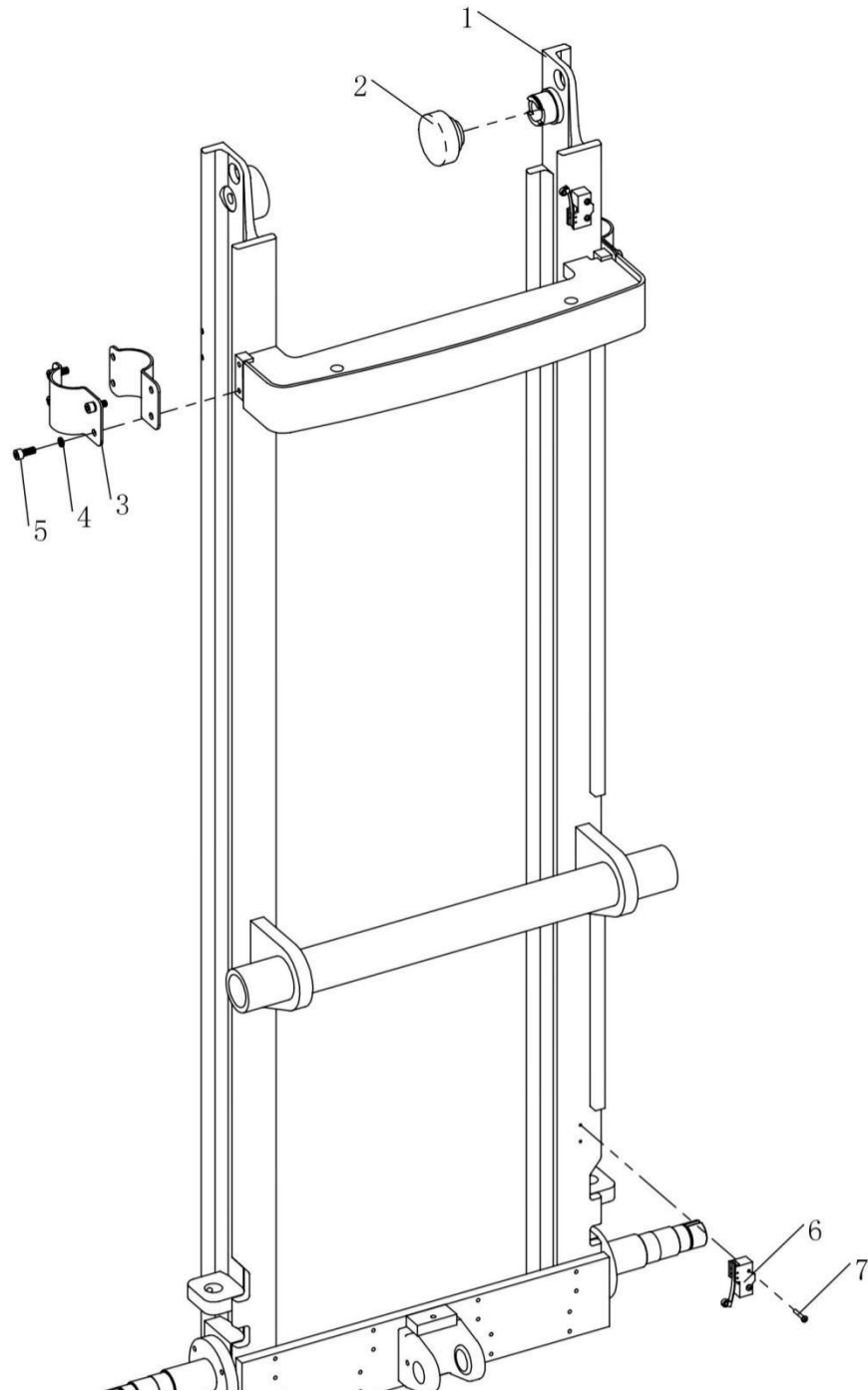

3.2 Componentes del marco exterior

Nº .	Código	Descripción	Especificación	Cantidad	Observ
1	E10GS-03.1.1	Outer frame welded		1	
2	CRA70.4-4S	Composite roller		2	
3	E10GS-03.1.4	Oil cylinder hoop		4	
4	GB/T 93-1987	Spring washer	Φ8	8	
5	GB/T 70.1-2000	Hexagon socket head cap screws	M8×20	8	
6	TY-01.35	MicroswitchRZ-15GW2S-B3		2	
7	GB/T 818-2000	Cross recessed pan head screw	M4×25	4	

3.3 Componentes del marco interior

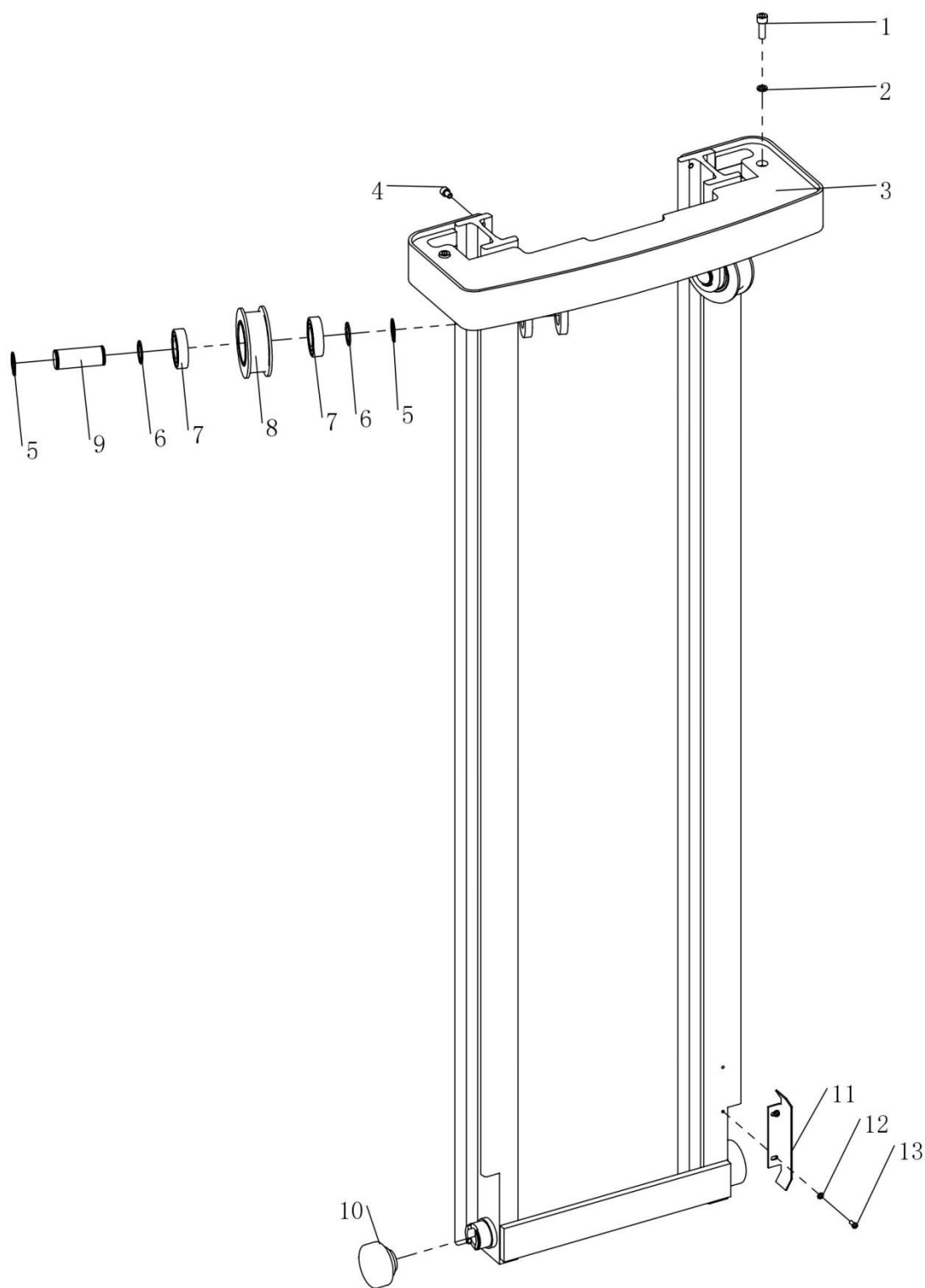

3.3 Componentes del marco interior

Nº .	Código	Descripción	Especificación	Cantidad	Observ
1	GB/T 70.1-2000	Hexagon socket head cap screws	M10×20	2	
2	GB/T 93-1987	Spring washer	Φ10	2	
3	E10GS-03.2.1	Inner frame welded		1	
4	GB/T 70.1-2000	Hexagon socket head cap screws	M8×12	2	
5	GB 894.1-86	Circlip for shaft	Φ30	4	
6	CG1646.03.3-8	Gasket		4	
7	GB/T 276-94	Deep groove ball bearing	6206-2Z	4	
8	CG1646.03.3-5	Chain wheel A		2	
9	CG1646.03.3-6	Chain wheel axle		2	
10	CRA70.4-4S	Composite roller		2	
11	E10GS-03.2.2	Stop plate		1	
12	GB/T 95-2002	Flat washer	Φ5	2	
13	GB/T 818-2000	Cross recessed pan head screw	M5×12	2	

3.4 Componentes del carro

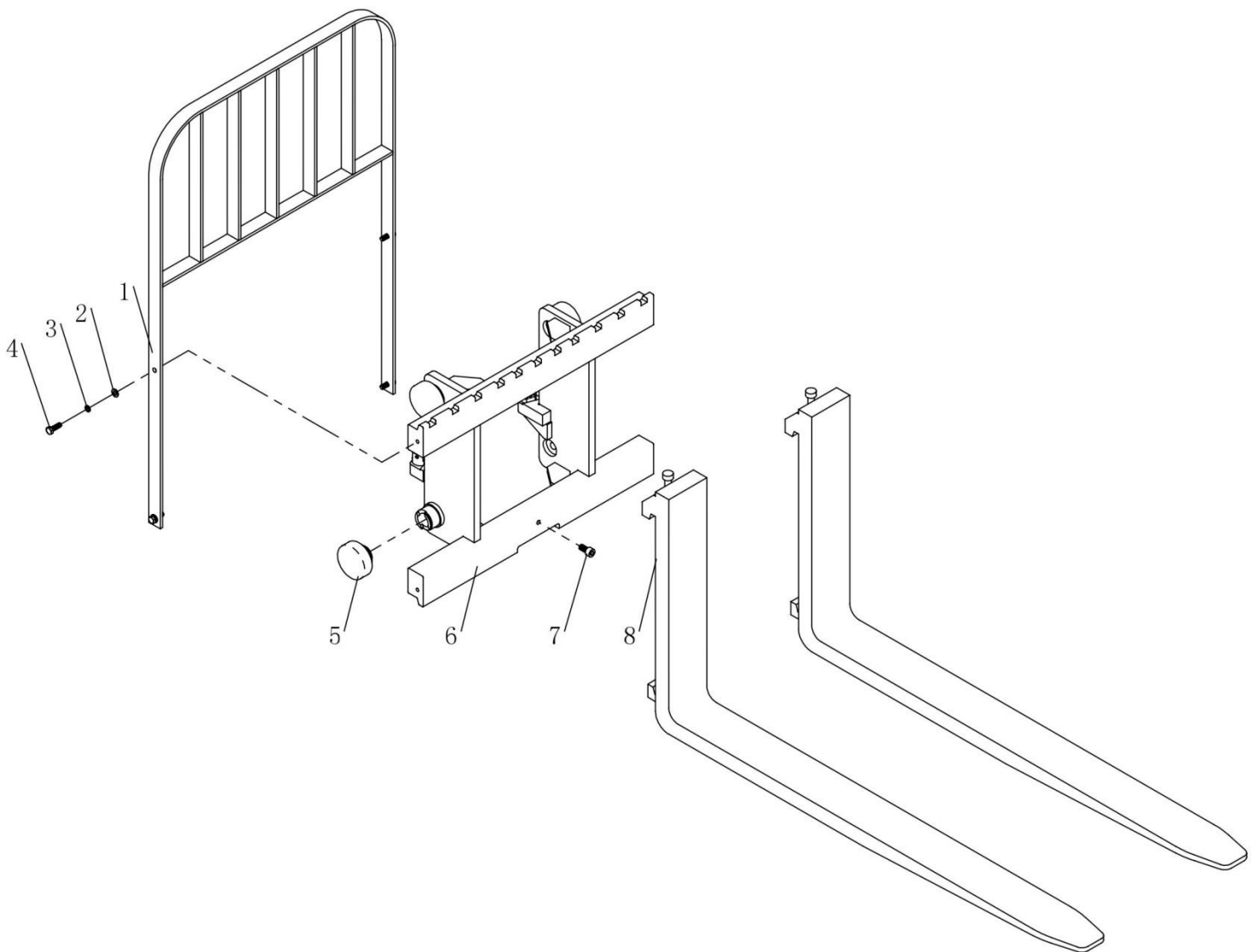

3.4 Componentes del carro

Nº .	Código	Descripción	Especificación	Cantidad	Observ
1	E10GS-03.3.2	Parapet wall welded		1	
2	GB/T 95-2002	Flat washer	Φ8	4	
3	GB/T 93-1987	Spring washer	Φ8	4	
4	GB/T 5781-2000	Hexagon bolt	M8×25	4	
5	CRA70.4-4S	Composite roller		4	
6	E10GS-03.3.1	Carriage welded		1	
7	GB/T 70.1-2000	Hexagon socket head cap screws	M10×20	1	
8	E10GS-03.3.3	Forks		2	

3.5 Conjunto de bastidor de triple mástil de elevación libre total

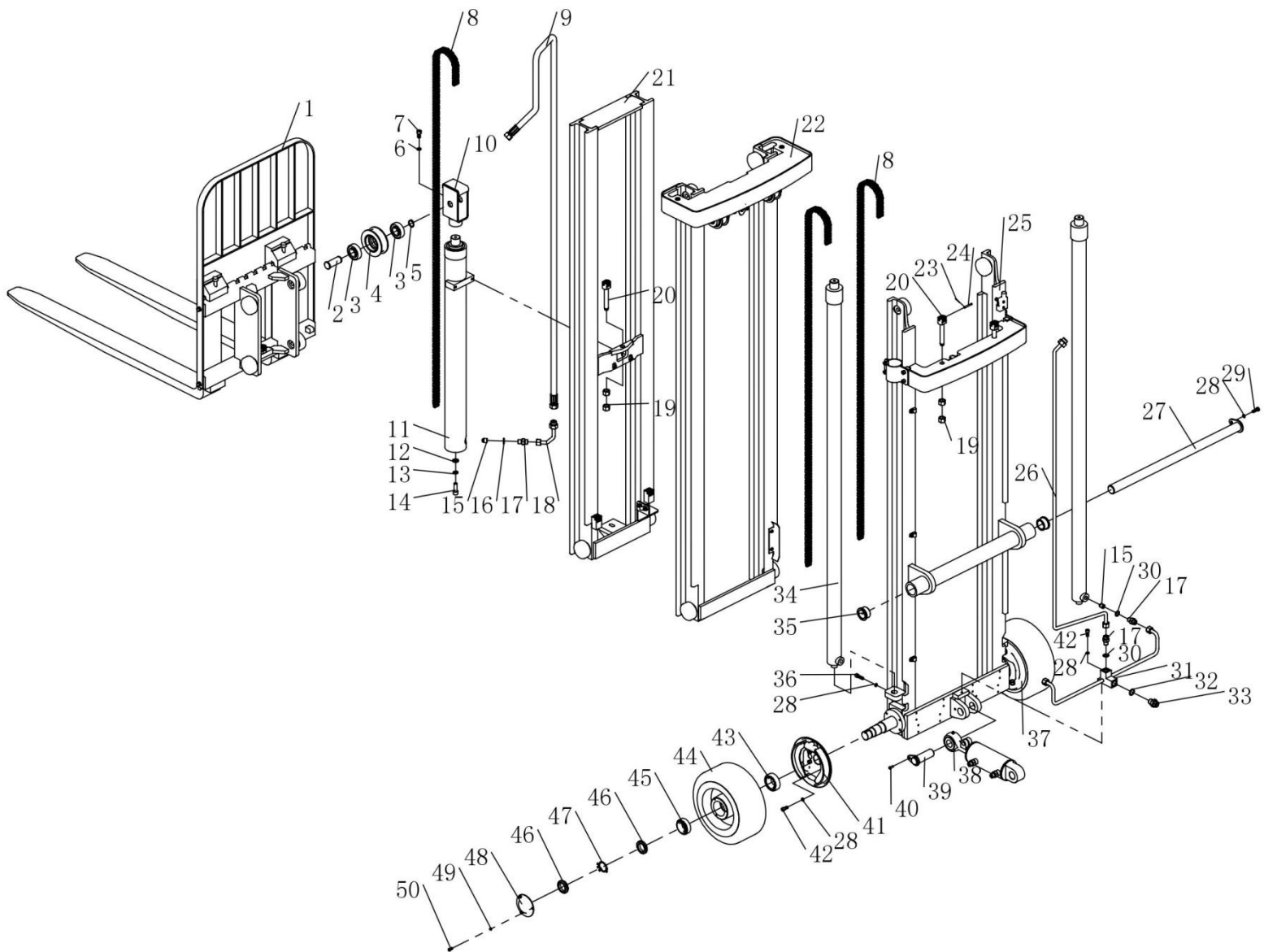

3.5 Conjunto de bastidor de triple mástil de elevación libre total

Nº .	Código	Descripción	Especificación	Cantidad	Observ
1	E10GS-07.4	Carriage components		1	
2	CL1032C.02-09	Chain bolt		1	
3	GB/T 276-94	Deep groove ball bearing	6305-2Z	2	
4	CG1646.03.3-5	Chain wheelA		1	
5	GB 894.1-86	Circlip for shaft	Φ25	1	
6	GB/T 93-1987	Spring washer	Φ10	1	
7	GB/T 70.1-2000	Hexagon socket head cap screws	M10×20	1	
8	LH0866	Leaf chain		3	
9	E10GS-07.9	High pressure rubber hose		1	
10	CL1555QD.02.07	Chain wheel rack welded		1	
11	E10GS-07.5	Lifting cylinder components in front		1	
12	GB/T 95-2002	Flat washer	Φ12	1	
13	GB/T 93-1987	Spring washer	Φ12	1	
14	GB/T 70.1-2000	Hexagon socket head cap screws	M12×35	1	
15	CL10.4.3	Explosion-proof valve core		3	
16	GB982-77	Combination gasket	Φ16	1	
17	E10GS-01.8.7	Straight Adapter		4	
18	E10GS-07.11	Steel tube (2)		1	
19	GB/T 41-2000	Hexagon nut	M16	6	
20	CG1646.02-4	Chain bolt		3	
21	E10GS-07.3	inner frame components		1	
22	E10GS-07.2	Middle frame components		1	
23	GB/T 91-2000	Cotter pin	Φ1.2×18	1	
24	GB 880-86	Pins with split pin hole	Φ5×40	2	
25	E10GS-07.1	Outer frame components		1	
26	E10GS-07.7	Steel tube (3)		1	
27	E10GS-03.7	Transmission shaft welded		1	
28	GB/T 93-1987	Spring washer	Φ8	12	
29	GB/T 5781-2000	Hexagon bolt	M8×25	1	
30	GB982-77	Combination gasket	Φ16	3	
31	E10GS-07.10	Steel tube (1)		1	
32	GB982-77	Combination gasket	Φ20	1	
33	E10GS-03.12	Adjustable Adapter		1	
34	E10GS-07.6	Lifting cylinder components in Rear		2	

35	E10GS-03.10	Connect copper sleeve		2	
36	GB/T 70.1-2000	Hexagon socket head cap screws	M8×30	2	
37	S11-3502020	Brake assembly Right		1	
38	E10GS-03.5	Inclined oil cylinder components		1	
39	E10GS-01.6	Inclined oil cylinder Pin shaft welded		1	
40	GB/T 70.2-2000	Hexagon socket flat head cap screws	M6×16	1	
41	S11-3502020	Brake assembly left		1	
42	GB/T 70.1-2000	Hexagon socket head cap screws	M8×20	9	
43	GB/T 297-94	Tapered roller bearing	33008	2	
44	CPD10A	Front wheel	Φ305×127	2	
45	GB/T 297-94	Tapered roller bearing	33007	2	
46	GB/T 812-1988	Round nut	M35×1.5	4	
47	GB 858-1988	Round nut With stop washer	Φ35	2	
48	E10GS-03.11	Front wheel side cover		2	
49	GB/T 93-1987	Spring washer	Φ6	6	
50	GB/T 65-2000	Slotted cap screw	M6×14	6	

3.6 Outer frame components (Triple mast full free lift)

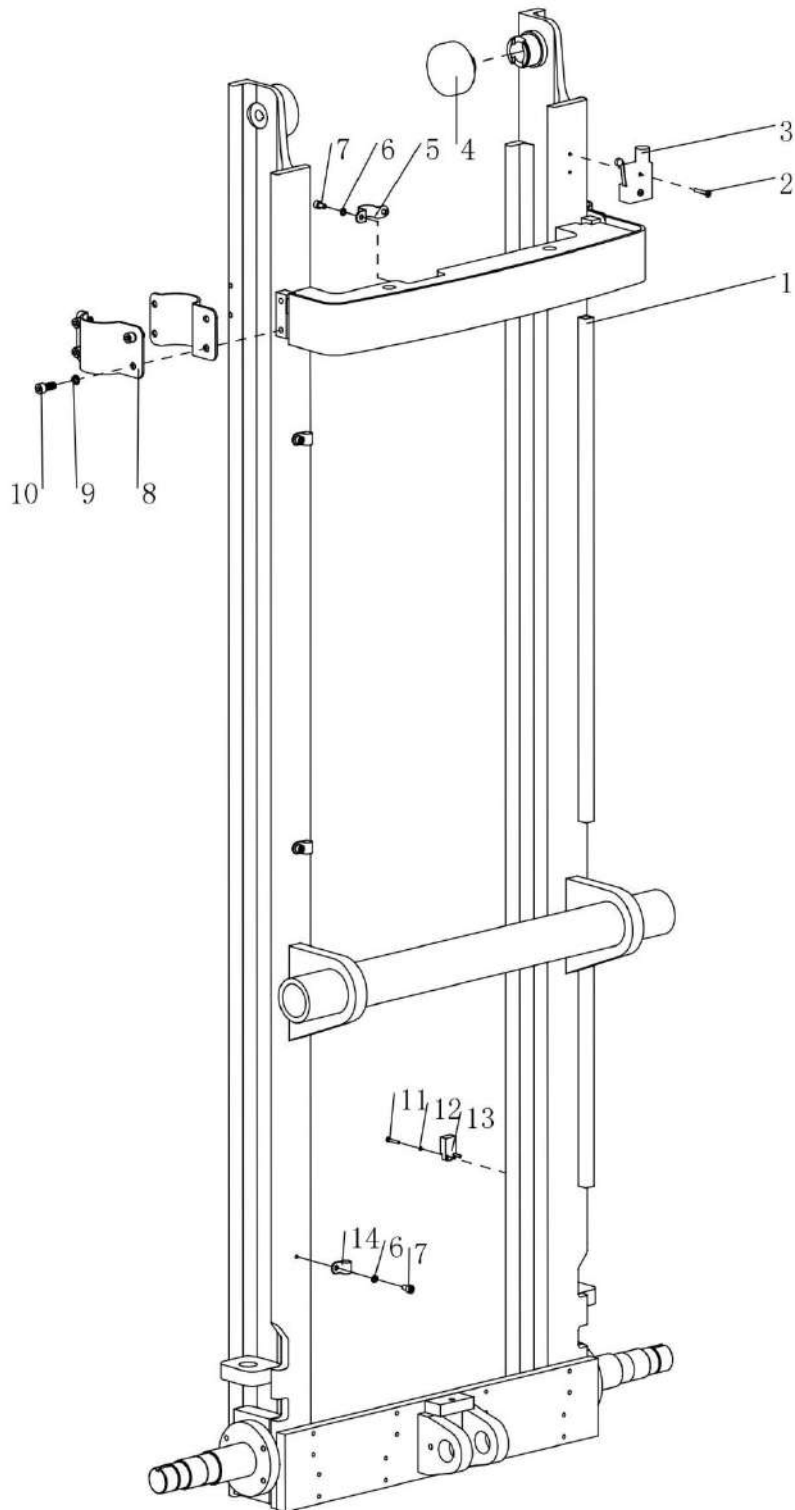

3.6 Outer frame components (Triple mast full free lift)

No.	Code	Description	Specification	Quantity	Remark
1	E10GS-07.1.1	Outer frame welded		1	
2	GB/T 818-2000	Cross recessed pan head screw	M4×25	2	
3	TY-01.35	MicroswitchRZ-15GW2S-B3		1	
4	CRA70.4-4S	Composite roller		2	
5		Hoop	Φ14	1	
6	GB/T 93-1987	Spring washer	Φ6	5	
7	GB/T 70.1-2000	Hexagon socket head cap screws	M6×10	5	
8	E10GS-03.1.4	Oil cylinder hoop		4	
9	GB/T 93-1987	Spring washer	Φ8	8	
10	GB/T 70.1-2000	Hexagon socket head cap screws	M8×20	8	
11	GB/T 818-2000	Cross recessed pan head screw	M3×20	2	
12	GB/T 93-1987	Spring washer	Φ3	2	
13	TY-01.38	Proximity switch CLJF20-05FA		1	
14		Tubing clamp	Φ12	3	

3.7 Componentes del bastidor central (mástil triple de elevación libre)

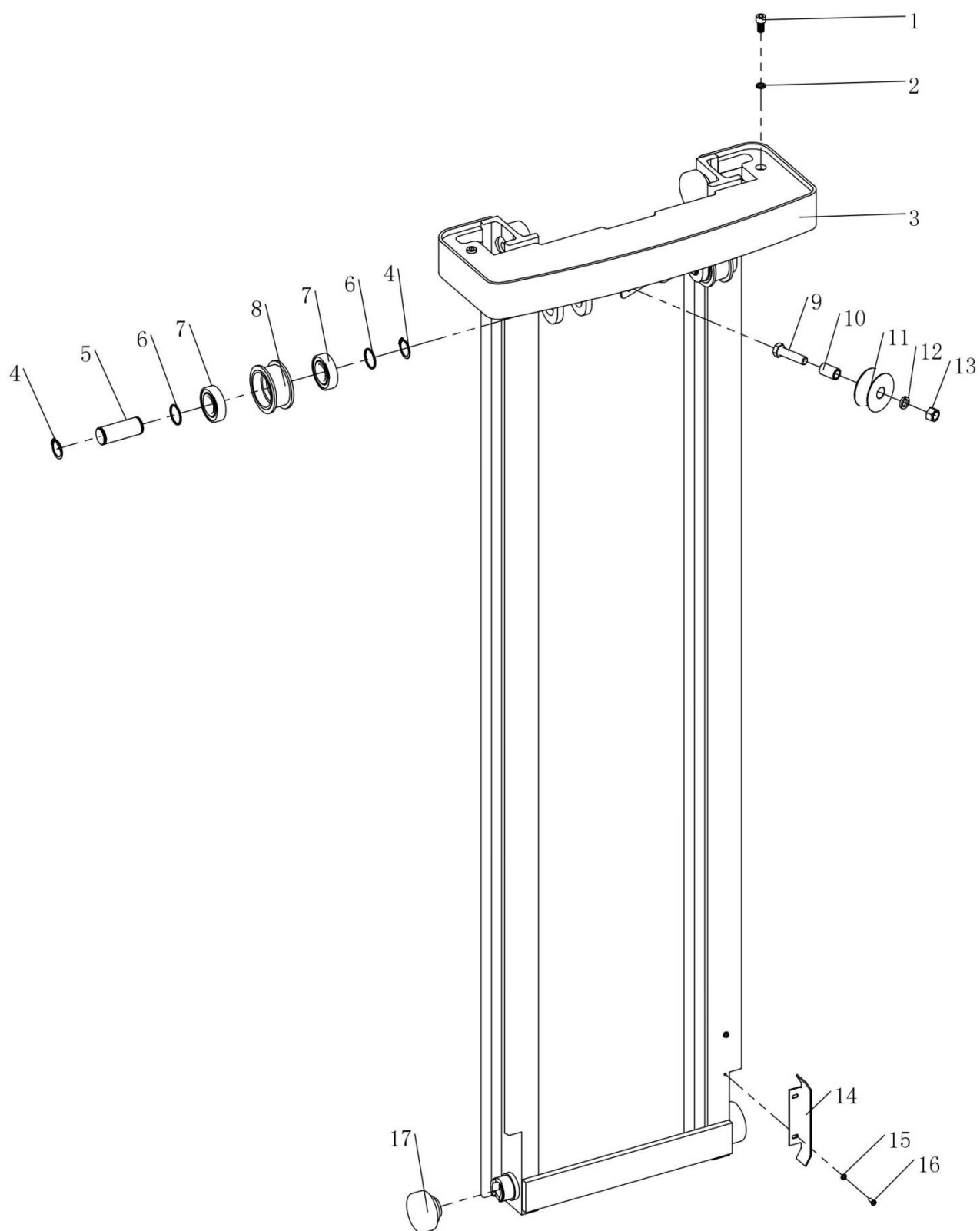

3.7 Middle frame components (Triple mast full free lift)

No.	Code	Description	Specification	Quantity	Remark
1	GB/T 70.1-2000	Hexagon socket head cap screws	M10×20	2	
2	GB/T 93-1987	Spring washer	Φ10	2	
3	E10GS-07.2.1	Middle frame welded		1	
4	GB 894.1-86	Circlip for shaft	Φ30	4	
5	CG1646.03.3-6	Chain wheel axle		2	
6	CG1646.03.3-8	Gasket		4	
7	GB/T 276-94	Deep groove ball bearing	6206-2Z	4	
8	CG1646.03.2-7	Chain wheel B		2	
9	GB/T 5781-2000	Hexagon head bolt full thread	M14×55	2	
10	E10GS-07.2.3	Carriage sleeve		2	
11	E10GS-07.2.2	roller		2	
12	GB/T 93-1987	Spring washer	Φ14	2	
13	GB/T 6184-2000	Hexagon lock nut	M14	2	
14	E10GS-03.2.2	Stop plate		1	
15	GB/T 95-2002	Flat washer	Φ5	2	
16	GB/T 818-2000	Cross recessed pan head screw	M5×12	2	
17	CRA70.4-4S	Composite roller		4	

3.8 Componentes del bastidor interior (triple mástil de elevación libre)

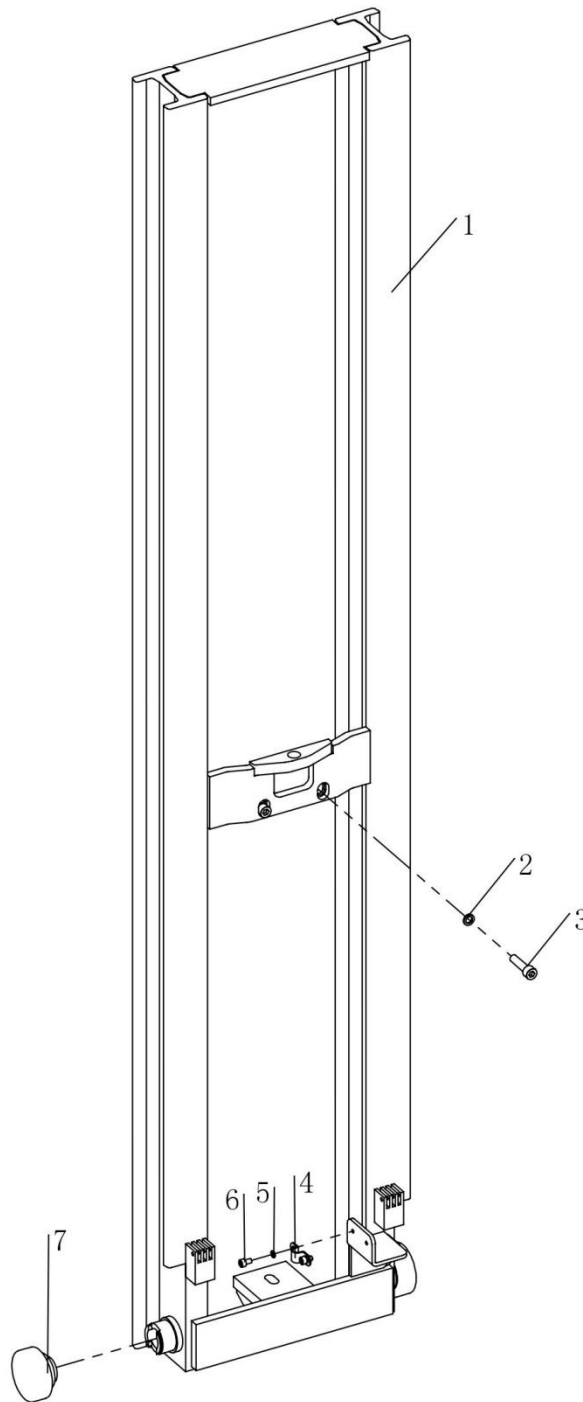

3.8 Componentes del bastidor interior (triple mástil de elevación libre)

Nº .	Código	Descripción	Especificación	Cantidad	Observ
1	E10GS-07.3.1	Inner frame welded		1	
2	GB/T 93-1987	Spring washer	Φ10	2	
3	GB/T 70.1-2000	Hexagon socket head cap screws	M10×40	2	
4		Hoop	Φ12	1	
5	GB/T 93-1987	Spring washer	Φ6	2	
6	GB/T 70.1-2000	Hexagon socket head cap screws	M6×10	2	
7	CRA70.4-4S	Composite rolle		2	

3.9 Componentes del carro (mástil triple de elevación libre)

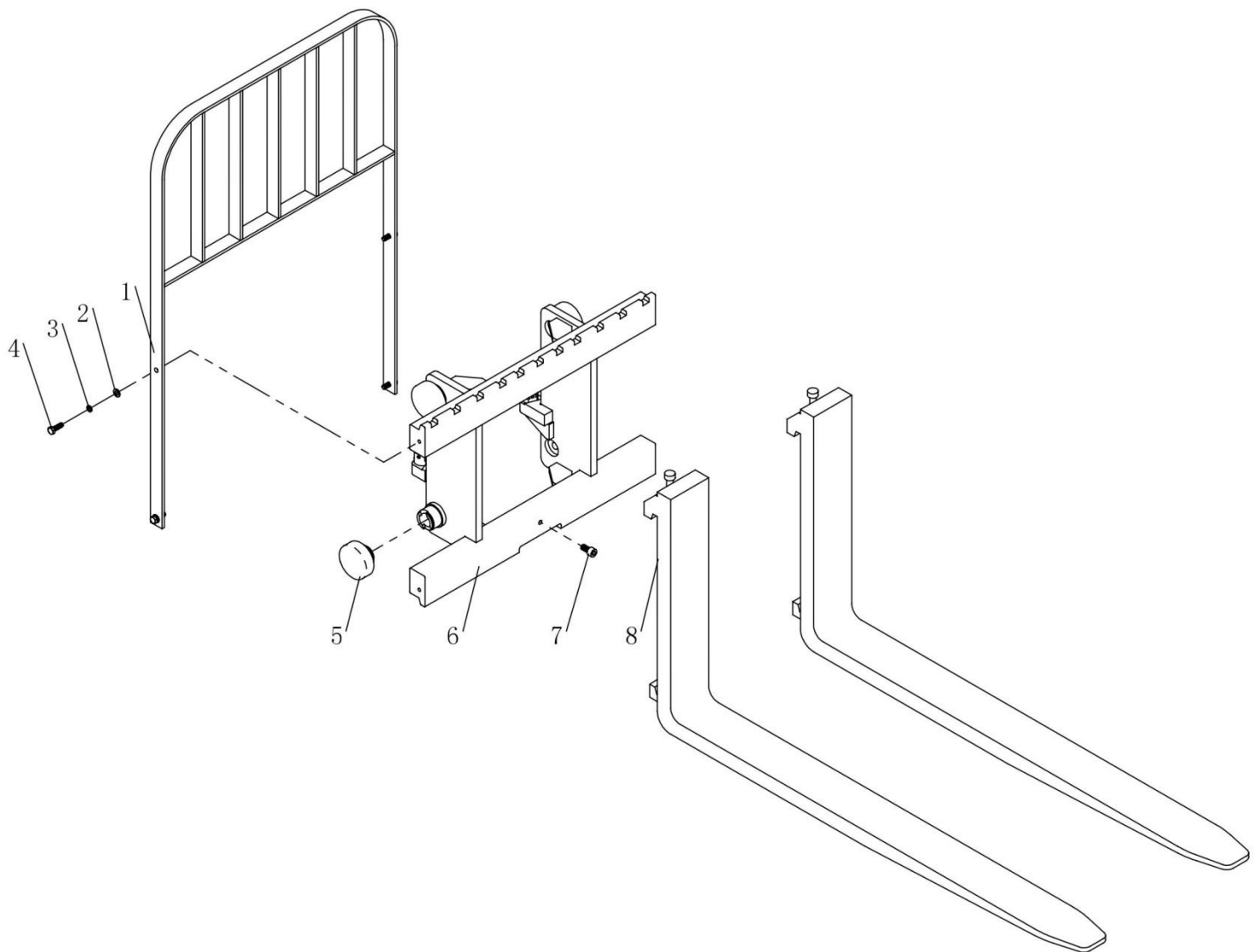

3.9 Componentes del carro (mástil triple de elevación libre)

Nº .	Código	Descripción	Especificación	Cantidad	Observ
1	E10GS-03.3.2	Parapet wall welded		1	
2	GB/T 95-2002	Flat washer	Φ8	4	
3	GB/T 93-1987	Spring washer	Φ8	4	
4	GB/T 5781-2000	Hexagon bolt	M8×25	4	
5	CRA70.4-4S	Composite roller		4	
6	E10GS-03.3.1	Carriage welded		1	
7	GB/T 70.1-2000	Hexagon socket head cap screws	M10×20	1	
8	E10GS-03.3.3	Forks		2	

3.10 Conjunto de mástil de dos etapas de elevación libre total

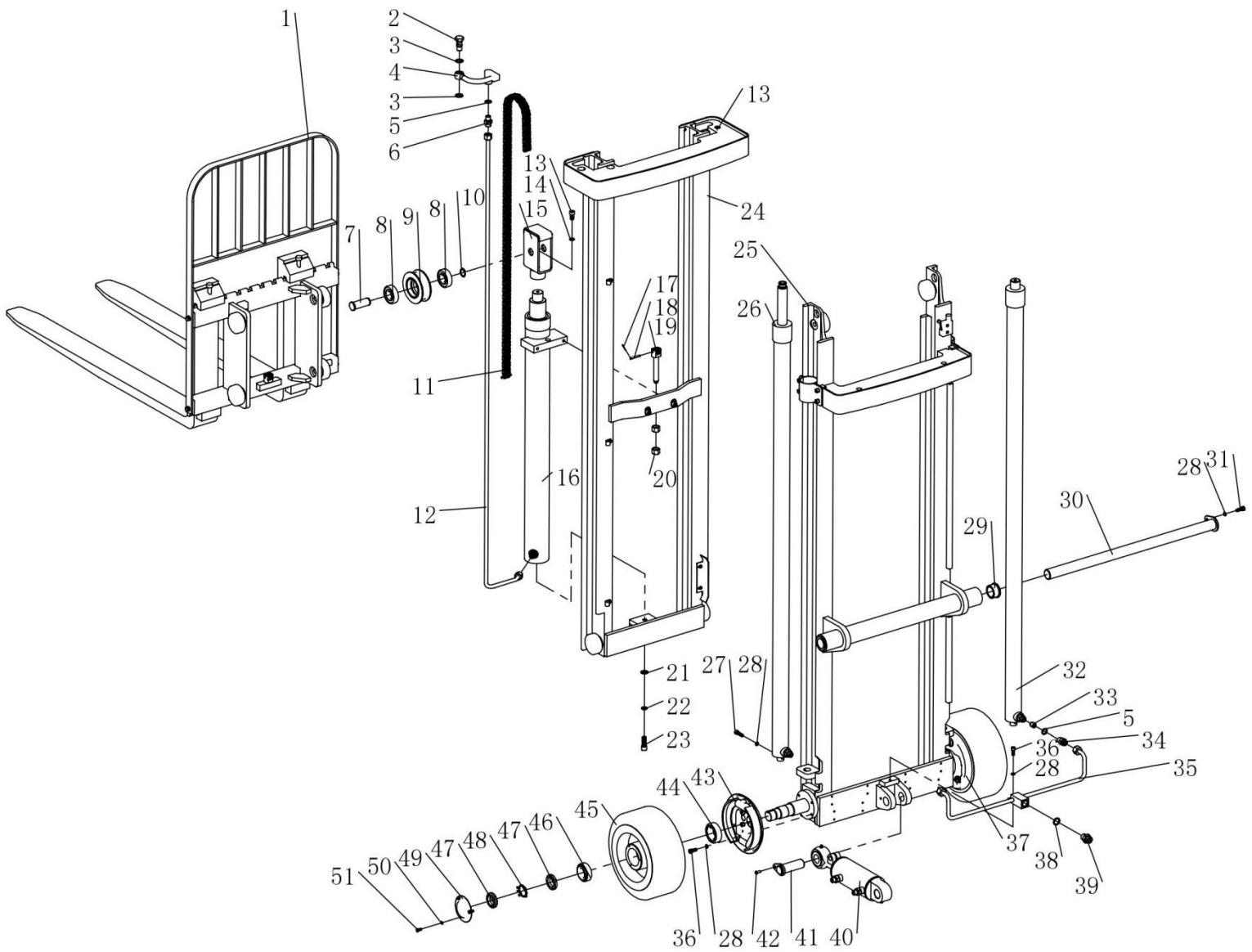

3.10 Conjunto de mástil de dos etapas elevación libre total

No.	Code	Description	Specification	Quantity	Remark
1	E10GS-08.3	Carriage components		1	
2	SPN10.8-11	Pump pipe joint		1	
3	GB982-77	Combination gasket	Φ18	2	
4	E10GS-08.6	Hydraulic steel pipe		1	
5	GB982-77	Combination gasket	Φ16	3	
6	E10GS-01.8.7	Straight adapter		1	
7	CL1032C.02-09	Chain wheel axle		1	
8	GB/T 276-94	Deep groove ball bearing	6305-2Z	2	
9	CG1646.03.3-5	Chain wheel A		1	
10	GB 894.1-86	Circlip for axle	Φ25	1	
11	LH0866	Leaf chain		1	
12	E10GS-08.7	High pressure oil pipe		1	
13	GB/T 70.1-2000	Hexagon socket head cap screw	M10×20	2	
14	GB/T 93-1987	Spring washer	Φ10	1	
15	CL1555QD.02.07	Chain wheel bracket welded		1	
16	E10GS-08.5	Lifting cylinder		1	
17	GB/T 91-2000	Cotter Pin	Φ1.2×18	2	
18	GB 880-86	Pins with split hole	Φ5×40	4	
19	CG1646.02-4	Chain bolt		1	
20	GB/T 41-2000	Hexagon nut	M16	2	
21	GB/T 95-2002	Flat washer	Φ12	1	
22	GB/T 93-1987	Spring whasher	Φ12	1	
23	GB/T 70.1-2000	Hexagon socket head cap screw	M12×35	1	
24	E10GS-03.2	Inner frame components		1	
25	E10GS-08.1	Outter frame components		1	
26	E10GS-08.4	Lifting cylinder components		1	
27	GB/T 70.1-2000	Hexagon socket head cap screw	M8×30	2	
28	GB/T 93-1987	Spring washer	Φ8	12	
29	E10GS-03.10	Connect copper sleeve		2	
30	E10GS-03.7	Transmission shaft welded		1	
31	GB/T 5781-2000	Hexagon bolt	M8×25	1	
32	E10GS-08.8	Lifting cylinder components		1	
33	CL10.4.3	Explosion-proof valve core		1	
34	E10GS-01.8.7	Straight adapter		2	
35	E10GS-03.9	Steel tube		1	
36	GB/T 70.1-2000	Hexagon socket head cap screw	M8×20	9	
37	S11-3502020	Brake assembly right		1	
38	GB982-77	Combination gasket	Φ20	1	

39	E10GS-03.12	Straight adapter		1	
40	E10GS-03.5	倾 inclined oil cylinder components		1	
41	E10GS-01.6	Inclined oil cylinder pin shaft welded		1	
42	GB/T 70.2-2000	Hexagon socket head cap screw	M6×16	1	
43	S11-3502020	Brake assembly left		1	
44	GB/T 297-94	Tapered roller bearing	33008	2	
45	CPD10A	Front wheel	305×127	2	
46	GB/T 297-94	Tapered roller bearing	33007	2	
47	GB/T 812-1988	Round nut	M35×1.5	4	
48	GB 858-1988	Round nut with stop washer	Φ35	2	
49	E10GS-03.11	Front wheel side cover		2	
50	GB/T 93-1987	Spring washer	Φ6	6	
51	GB/T 65-2000	Slotted cheese-head screw	M6×14	6	

3.11 Componentes del bastidor exterior (mástil de dos etapas de elevación libre)

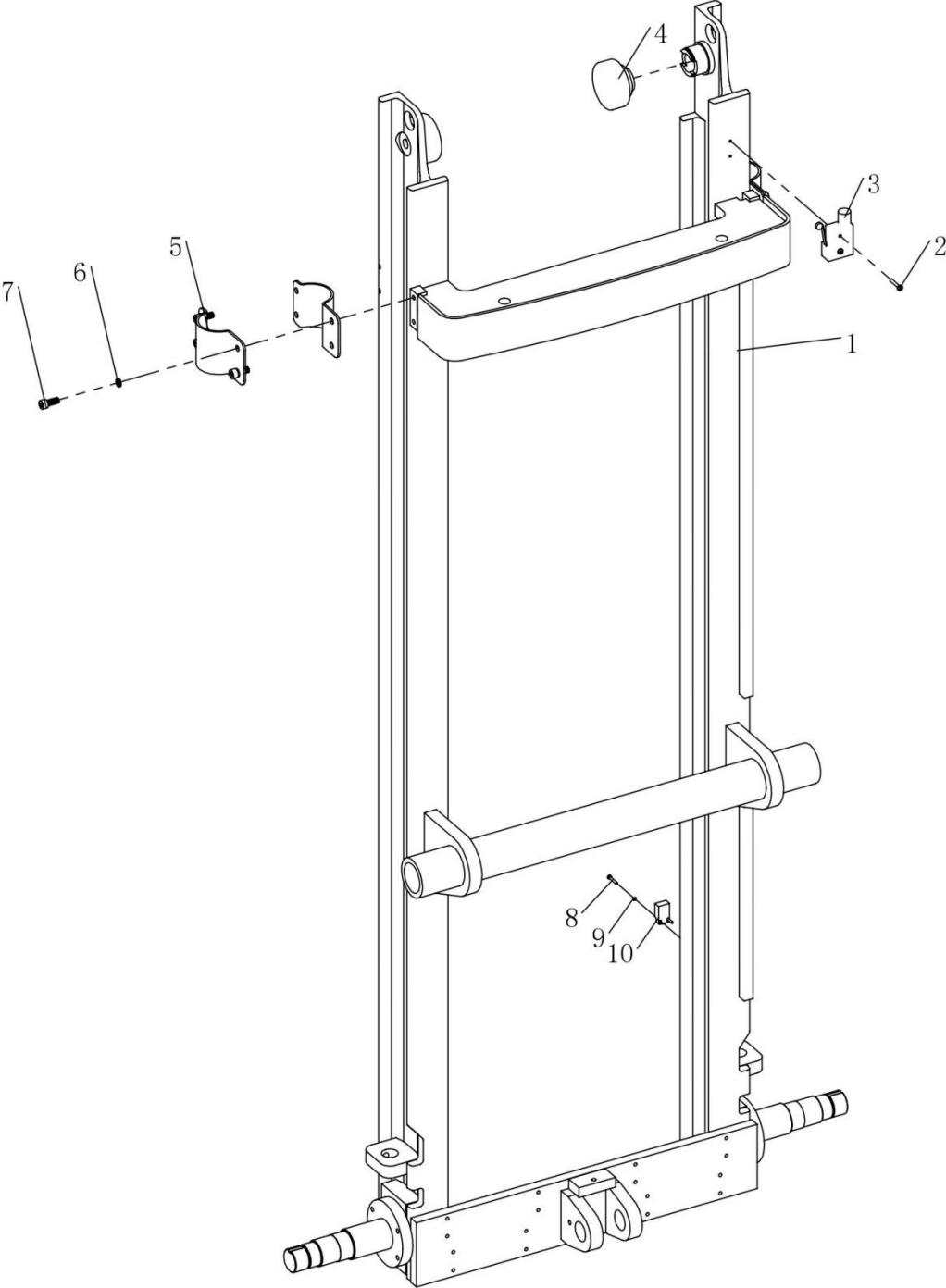

3.11 Componentes del bastidor exterior (mástil de dos etapas de elevación libre)

Nº .	Código	Descripción	Especificación	Cant.	Observ
1	E10GS-08.1.1	Outer frame welded		1	
2	GB/T 818-2000	Cross recessed pan head screw	M4×25	2	
3	TY-01.35	MicroswitchRZ-15GW2S-B3		1	
4	CRA70.4-4S	Composite roller		2	
5	E10GS-03.1.4	Oil cylinder hoop		4	
6	GB/T 93-1987	Spring washer	Φ8	8	
7	GB/T 70.1-2000	Hexagon socket head cap screws	M8×20	8	
8	GB/T 818-2000	Cross recessed pan head screw	M3×20	2	
9	GB/T 93-1987	Spring washer	Φ3	2	
10	TY-01.38	Proximity switch CLJF20-05FA		1	

3.12 Componentes del bastidor interior (mástil de dos etapas de elevación libre)

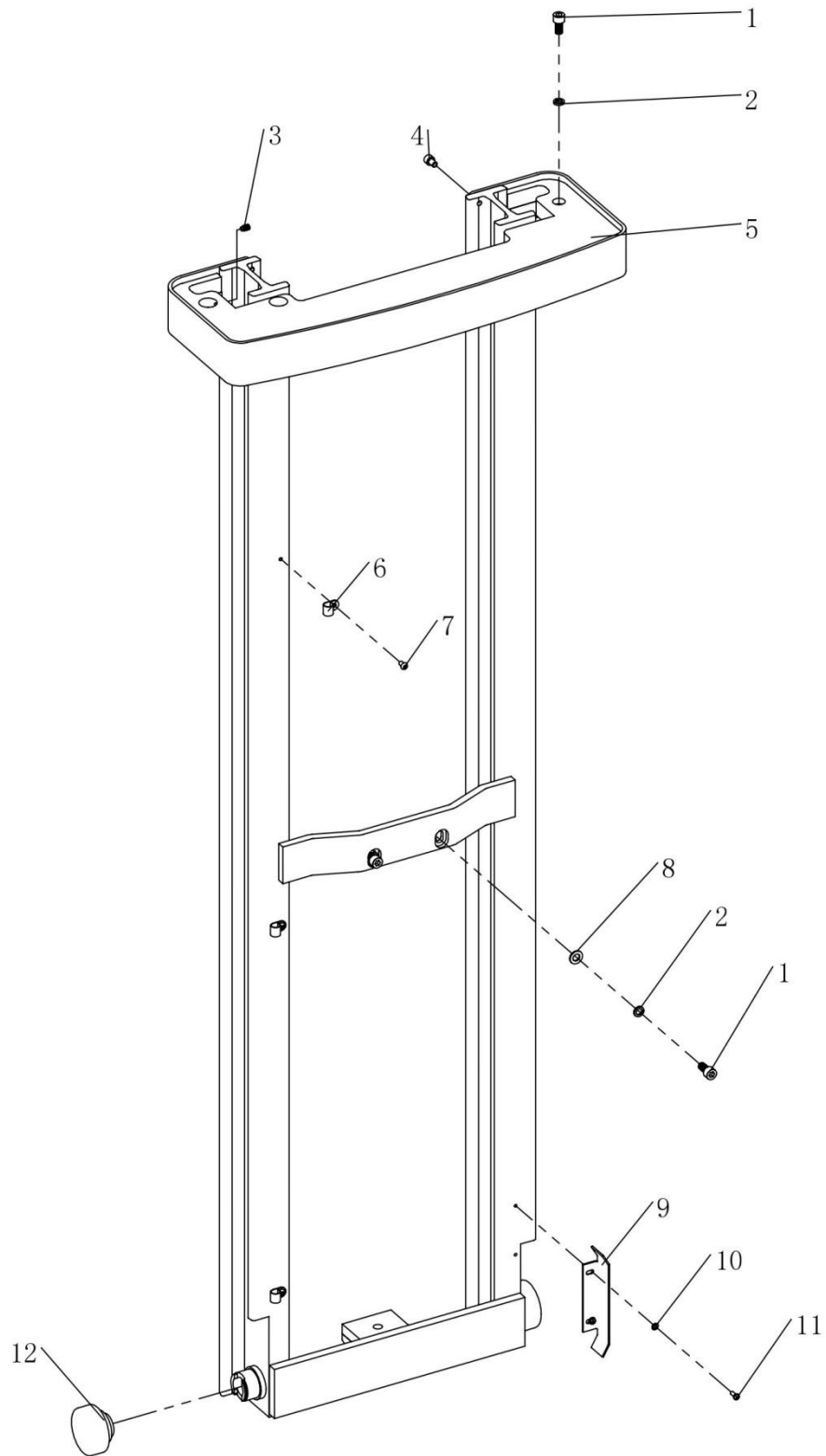

3.12 Componentes del bastidor interior (mástil de dos etapas de elevación libre)

No.	Code	Description	Specification	Quantity	Remark
1	GB/T 70.1-2000	Hexagon socket head cap screws	M10×20	3	
2	GB/T 93-1987	Spring washer	Φ10	3	
3	GB/T 79-2000	Hexagon socket set screws with dog point	M8×12	1	
4	GB/T 70.1-2000	Hexagon socket head cap screws	M8×12	2	
5	E10GS-08.2.1	Inner frame welded		1	
6		Tubing hoop	Φ12	3	
7	GB/T 70.2-2000	Hexagon socket button head screws	M6×10	3	
8	GB/T 95-2002	Flat washer	Φ10	2	
9	E10GS-03.2.2	Stop plate		1	
10	GB/T 95-2002	Flat washer	Φ5	2	
11	GB/T 818-2000	Cross recessed pan head screw	M5×12	2	
12	CRA70.4-4S	Composite roller		2	

3.13 Componentes del carro (mástil de dos etapas de elevación libre)

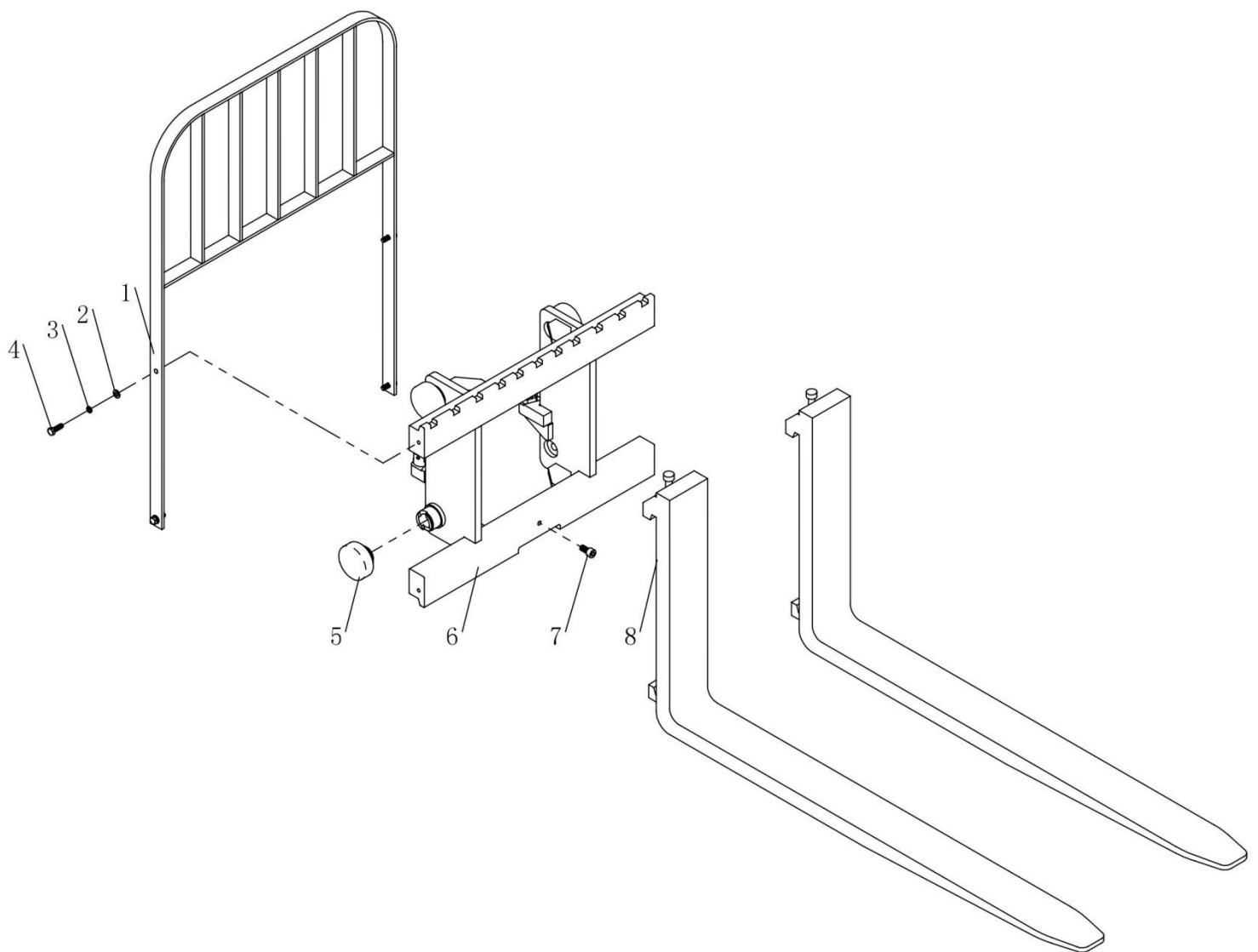

3.13 Componentes del carro (mástil de dos etapas de elevación libre)

No.	Code	Description	Specification	Quantity	Remark
1	E10GS-03.3.2	Parapet wall welded		1	
2	GB/T 95-2002	Flat washer	Φ8	4	
3	GB/T 93-1987	Spring washer	Φ8	4	
4	GB/T 5781-2000	Hexagon bolt	M8×25	4	
5	CRA70.4-4S	Composite roller		4	
6	E10GS-03.3.1	Carriage welded		1	
7	GB/T 70.1-2000	Hexagon socket head cap screws	M10×20	1	
8	E10GS-03.3.3	Forks		2	

4.1 Montaje de la tapa de la batería

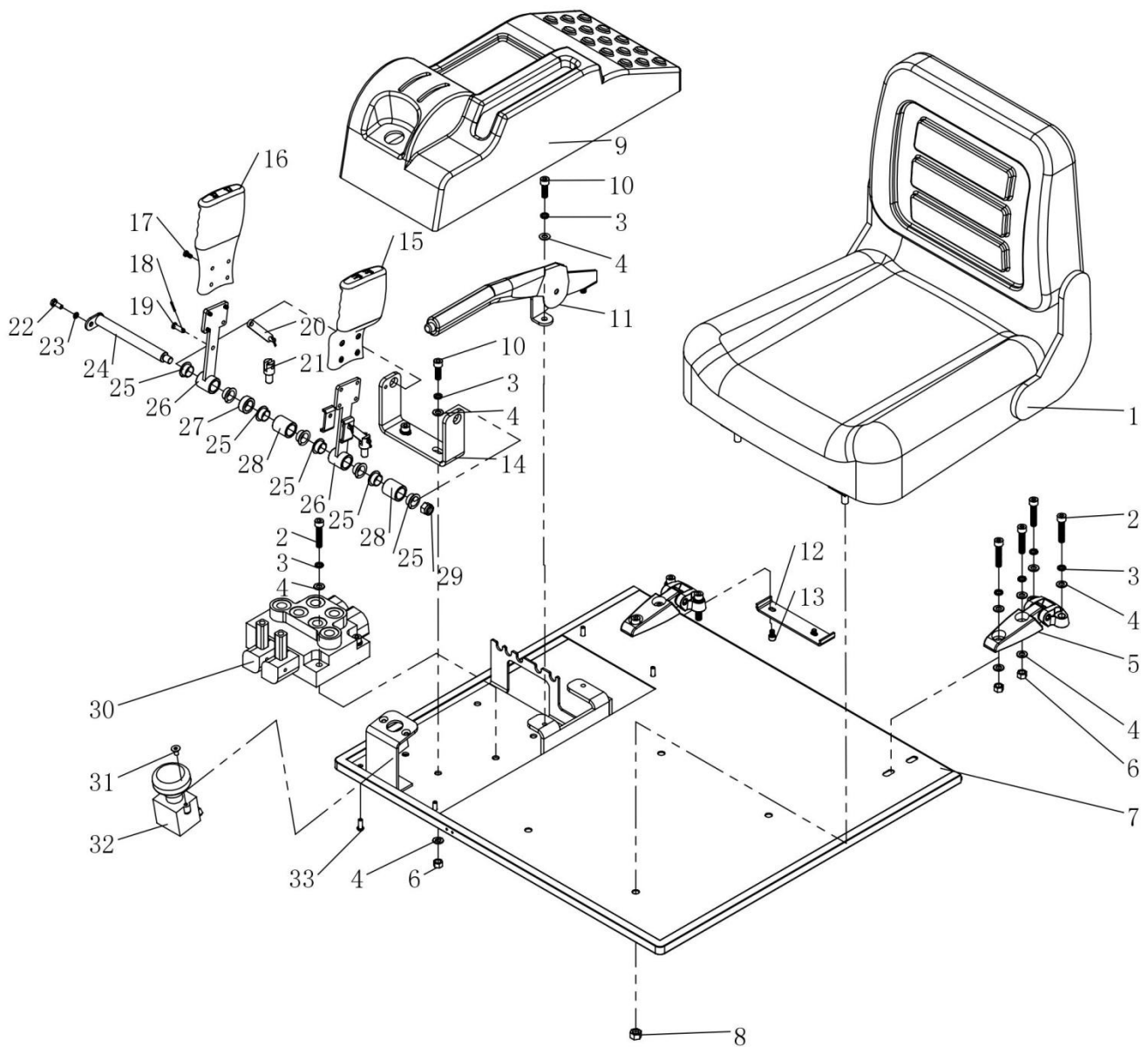

4.1 Montaje de la tapa de la batería

Nº .	Código	Descripción	Especificaciones	Cantidad	Observ
1		Seat		1	
2	GB/T 70.1-2000	Hexagon socket head cap screws	M8×40	8	
3	GB/T 93-1987	Spring washer	Φ8	12	
4	GB/T 97.2-1985	Flat washer	Φ8	18	
5		Forks hinge		2	
6	GB/T 41-2000	Hexagon nut	M8	6	
7	E10GS-04.1	Battery cover welded		1	
8	GB/T 41-2000	Hexagon nut	M10	4	
8	E10GS-04.5	Multiple valve mask		1	
9	GB/T 70.1-2000	Hexagon socket head cap screws	M8×25	4	
10		Hand brake		1	
11	E10GS-04.10	Fixed bracket		1	
12	GB/T 70.1-2000	Hexagon socket head cap screws	M6×10	2	
13	E10GS-04.13	Handle bracket		1	
14	E10GS-04.8	Lifting handle		1	
15	E10GS-04.9	Tilting handle		1	
16	GB/T 91-2000	Split pin	Φ2×16	4	
17	GB 882-88	Pin roll	Φ6×12	4	
18	E10GS-04.7	Valve lever		2	
19	GB/T 818-2000	Cross recessed pan head screw	M5×10	8	
20	E10GS-04.6	Multi-way valve analog lever		2	
21	GB/T 5781-2000	Hexagon head bolt full thread	M6×25	1	
22	GB/T 93-1987	Spring washer	Φ6	1	
23	E10GS-04.3	Ear plate welded		1	
24	E10GS-04.12	Handle spacer left		2	
25	E10GS-04.2	Valve handle parts		2	
26	E10GS-04.11	Handle spacer middle		1	
27	GB/T 889.1-2000	Hexagon lock nut	M10	1	
28	GB/T 70.3-2000	Socket cap screw	M6×12	2	
29	TY-01.36	Emergency stop switch ED125-2-1		1	
30	GB/T 70.2-2000	Hexagon socket button head screws	M6×16	4	

5.1 Cobertura del cuadro de mando

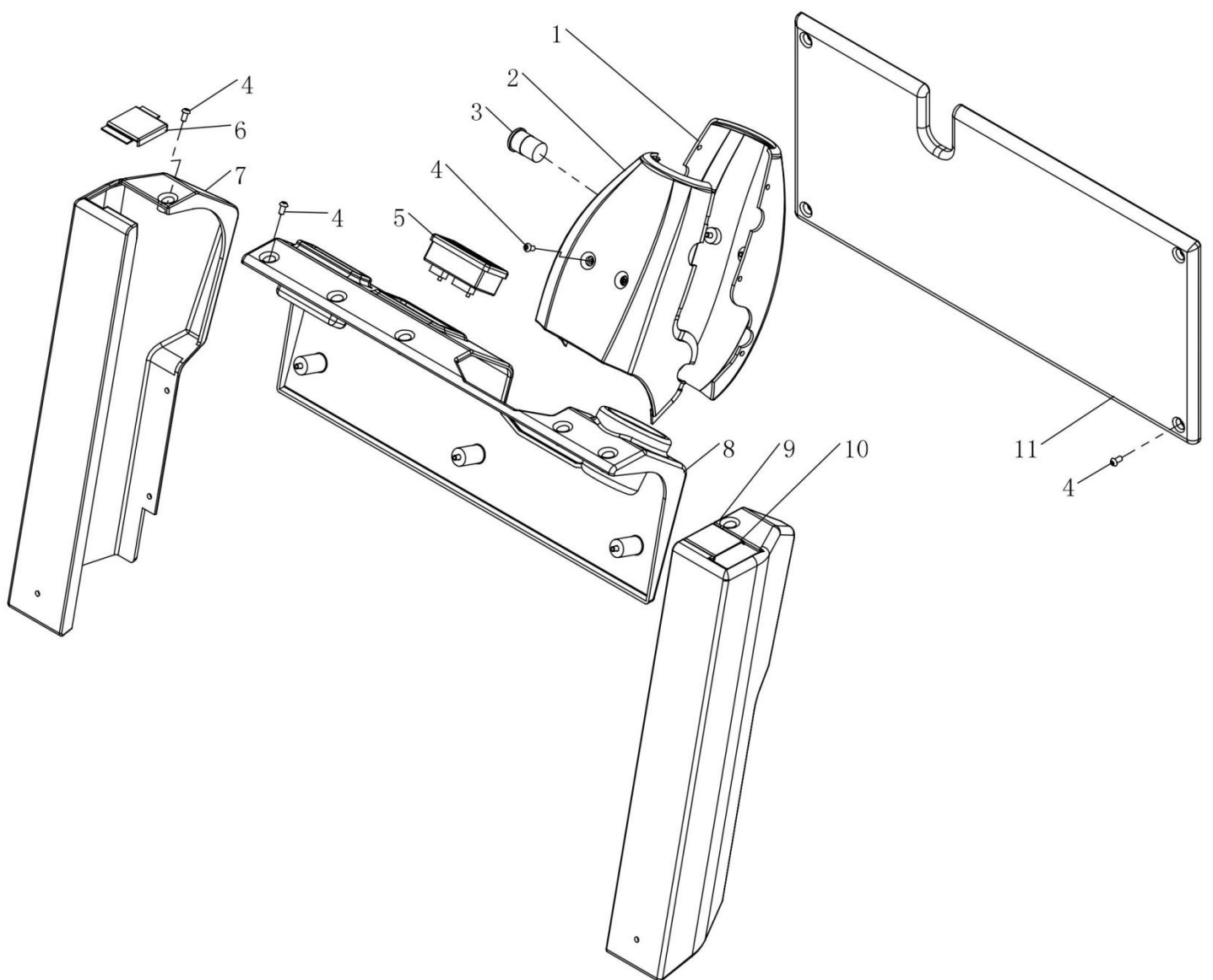

Cobertura del cuadro de mando

Nº .	Código	Descripción	Especificación	Cant.	Observ
1	E10GS-10	Column rear cover		1	
2	E10GS-09	Column front cover		1	
3	TY-01.17	XF125 Electric lock		1	
4	GB/T 70.2-2000	Hexagon socket button head screw	M6×12	18	
5	950T48	Coulombmeter		1	
6	E10GS-06.8	Dashboard side cover close plate (Right)		1	
7	E10GS-08	Dashboard side cover (Right)		1	
8	E10GS-06.1	Dashboard side cover		1	
9	E10GS-07	Dashboard side cover (left)		1	
10	E10GS-06.7	Dashboard side cover close plate (Left)		1	
11	E10GS-06..6	Close plate		1	

6.1 Sistema hidráulico

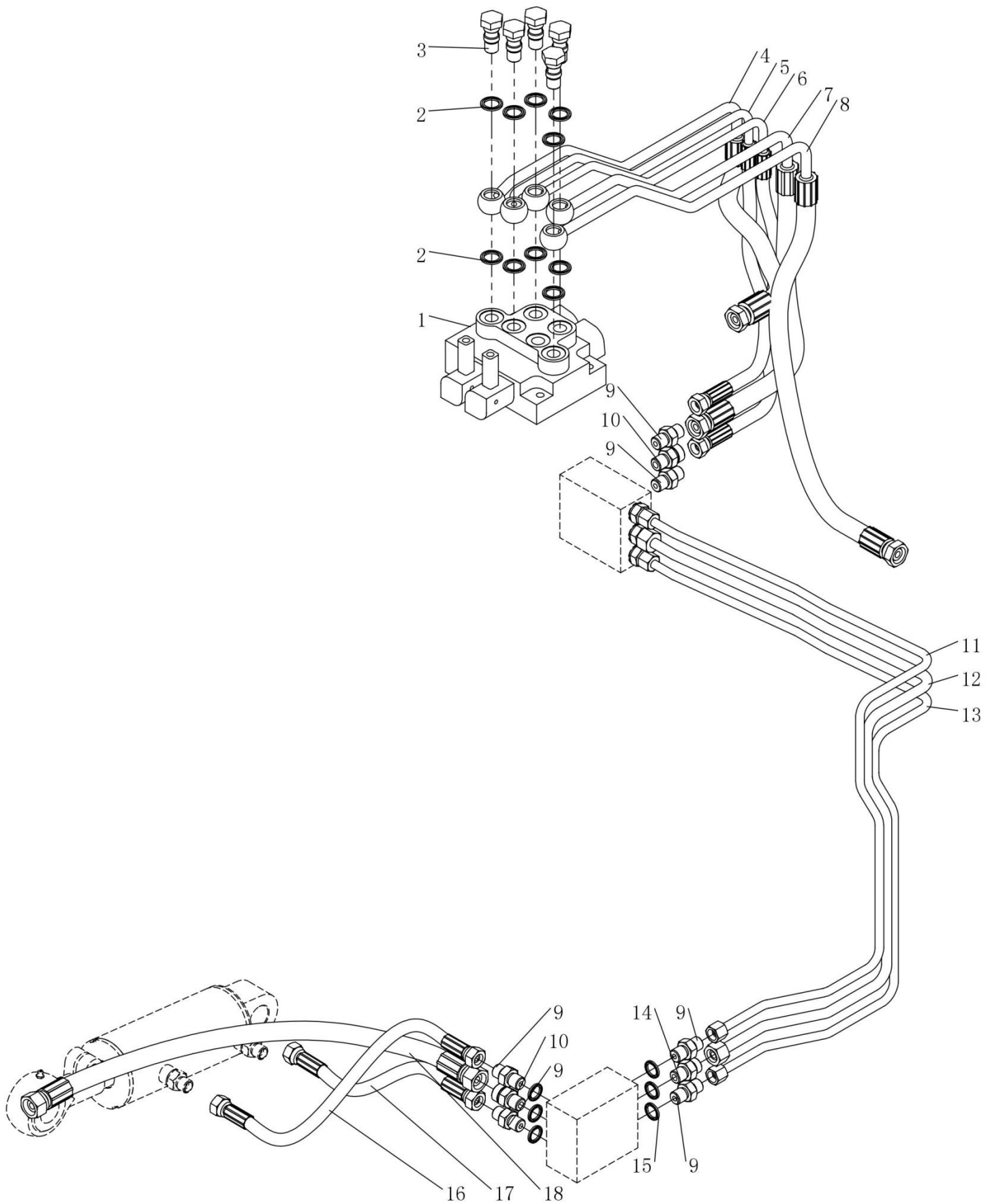

6.1 Sistema hidráulico

Nº .	Código	Descripción	Especificación	Cant.	Observ
1	6070-DCL	Multiple valve		1	
2	GB982-77	Combination gasket	Φ18	10	
3	SPN10.8-11	Pump pipe jjoint		5	
4	E10GS-04.4.4	High pressure rubber hose7		1	
5	E10GS-04.4.3	High pressure rubber hose6		1	
6	E10GS-04.4.2	High pressure rubber hose5		1	
7	E10GS-04.4.1	High pressure rubber hose4		1	
8	E10GS-04.4.5	High pressure rubber hose8		1	
9	CG1646.05.1-4	Straight Adapter		8	
10	E10GS-01.8.8	Straight Adapter		2	
11	E10GS-01.8.1	Bend Pipe 1		1	
12	E10GS-01.8.2	Bend Pipe2		1	
13	E10GS-01.8.3	Bend Pipe3		1	
14	E10GS-01.8.7	Straight Adapter		2	
15	GB982-77	Combination gasket	Φ16	12	
16	E10GS-01.8.5	High pressure rubber hose2		1	
17	E10GS-01.8.4	High pressure rubber hose1		1	
18	E10GS-01.8.6	High pressure rubber hose3		1	

7.1 DK1232-01 Componentes de control eléctrico de corriente alterna

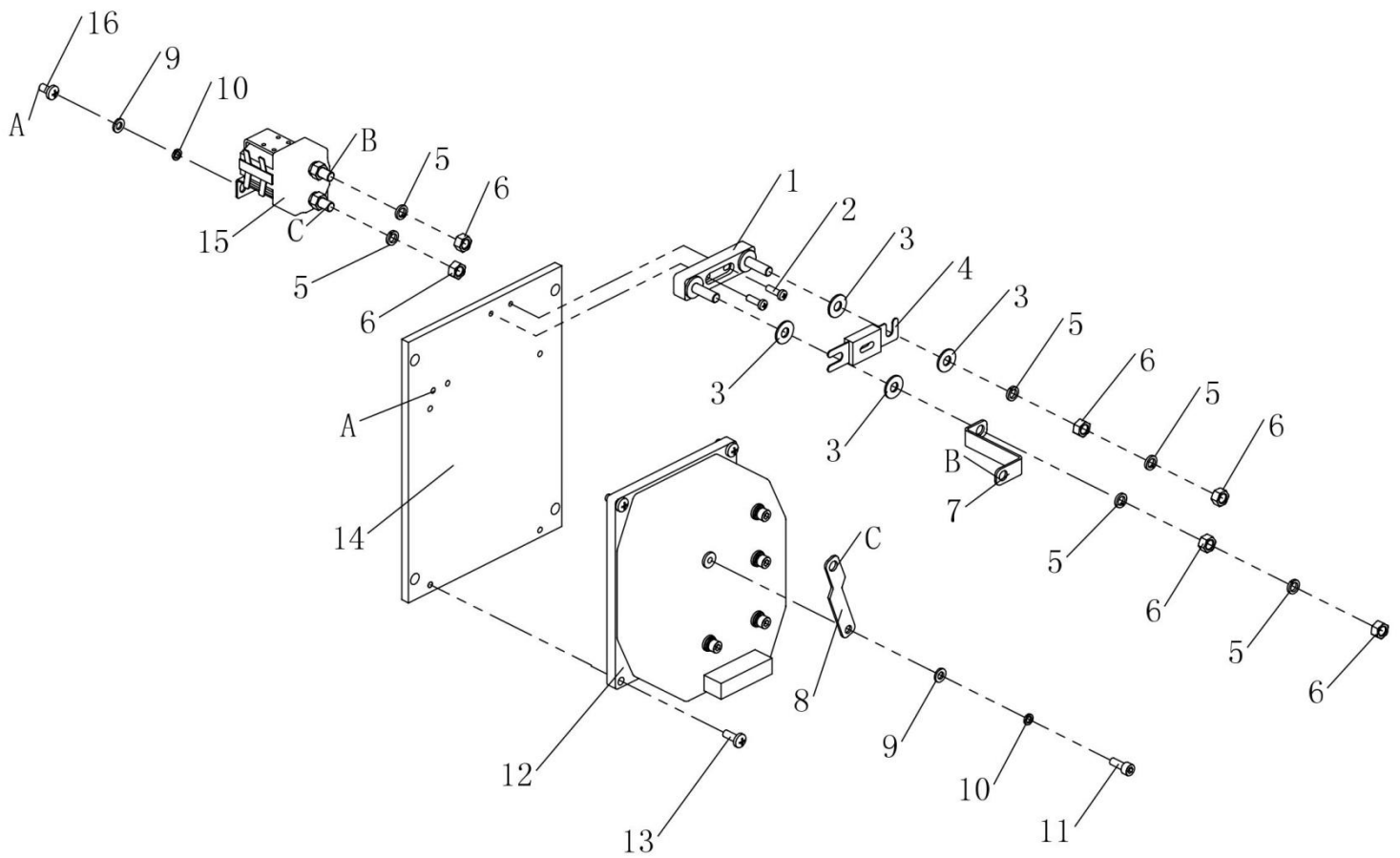

7.1 DK1232-01 Componentes de control eléctrico de corriente alterna

Nº .	Código	Descripción	Especificación	Cantidad	Observ
1	TY-02.32	Fuse base		1	
2	GB/T 818-2000	Cross recessed pan head screw	M5×16	2	
3		Copper gasket		4	
4	TY-01.1	Fuse	200A	1	
5	GB/T 93-1987	Spring washer	Φ8	6	
6	GB/T 6170-2000	Hexagon nut	M8	6	
7	DK1230-01.2	Copper sheet (1)		1	
8	DK1232-01.2	Copper sheet (3)		1	
9	GB/T 95-2002	Flat washer	Φ6	7	
10	GB/T 93-1987	Spring washer	Φ6	7	
11	GB/T 70.1-2000	Hexagon socket head cap screws	M6×16	5	
12	1232E	AC electric controller		1	
13	GB/T 818-2000	Cross recessed pan head screw	M6×16	4	
14	DK1232-02.1	Electric controller mounting plate		1	
15	TY-01.41	Relay	SW80	1	
16	GB/T 818-2000	Cross recessed pan head screw	M6×12	2	